

4205 SIDE SCAN SYSTEM

USER HARDWARE MANUAL

0021769_REV_J

02/19/2025

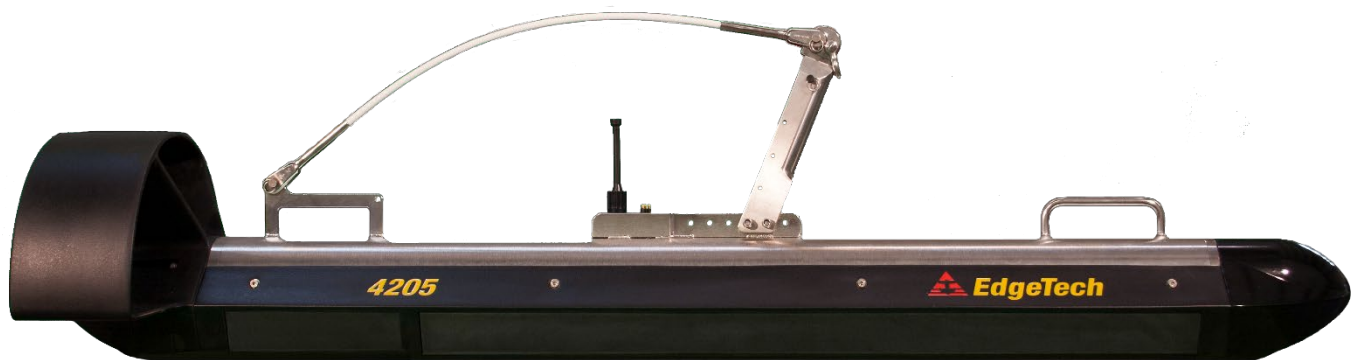

EdgeTech

4 Little Brook Road
West Wareham, MA 02576

Tel: (508) 291-0057

Fax: (508) 291-2491

www.EdgeTech.com

The information, figures, and specifications in this manual are proprietary. They are issued in strict confidence on condition that they not be copied, reprinted, or disclosed to a third party, either wholly or in part, without the prior written consent of EdgeTech. Any reproduction of EdgeTech-supplied software or file sharing is strictly prohibited.

Copyright © 2018-2024 EdgeTech. All rights reserved.

Microsoft Windows© is a registered trademark of Microsoft Corporation

SBG© is a registered trademark of SBG Systems

Storm Case® is a registered trademark of Pelican.

SKB® is a registered trademark of the SKB Corporation, Inc.

ATTENTION – READ THIS FIRST!

All personnel involved with installing, operating, or maintaining the equipment described in this manual should read and understand the warnings and cautions provided below.

CAUTION! This equipment contains devices that are extremely sensitive to static electricity. Therefore, extreme care should be taken when handling them. Normal handling precautions involve using anti-static protection materials and grounding straps for personnel.

WARNING! High voltage may be present in all parts of the system. Therefore, use caution when the electronics are removed from their containers for servicing.

CAUTION! Operation with improper line voltage may cause serious damage to the equipment. Always ensure that the proper line voltage is used.

Warnings, Cautions, and Notes

Where applicable, warnings, cautions, and notes are provided in this manual as follows:

WARNING! Identifies a potential hazard that could cause injury or death.

CAUTION! Identifies a potential hazard that could damage equipment or data.

NOTE: Recommendations or general information particular to the material being presented.

HARDWARE VARIATIONS AND COMPATIBILITY

The 4205 Side Scan System contains both standard and proprietary hardware. At times, EdgeTech may change the standard components due to their availability or performance improvements. Although the component manufacturers and their models and styles may change from unit to unit, replacement parts will generally be interchangeable.

EdgeTech will make every effort to see that replacement components are interchangeable and use the same software drivers (if applicable). At times, however, direct replacements may not exist. When this happens, EdgeTech will provide the necessary drivers with the replacement part, if applicable.

EdgeTech may also change certain hardware per customer requirements. Therefore, portions of this manual, such as parts lists and test features, are subject to change. These sections should be used for reference only. When changes that affect system operation are made, they will be explicitly noted. Also, some options and features may not be active in the customer's unit at the time of delivery. Upgrades will be made available when these features are implemented.

Contact **CUSTOMER SERVICE** with any questions relating to compatibility.

ABOUT THIS DOCUMENT

We, the employees at EdgeTech, would like to thank you for purchasing a 4205 Side Scan System. At EdgeTech, our policy is to provide high-quality, cost-effective products and support services that meet or exceed your requirements. We also strive to deliver them on time and continuously look for ways to improve them. We take pride in the products we manufacture and want you to be entirely satisfied with your equipment.

Purpose of this Manual

The purpose of this manual is to provide you with information on the setup and use of EdgeTech's 4205 Side Scan System. Although this manual encompasses the latest operational features of the 4205, some features may be periodically upgraded. Therefore, the information in this manual is subject to change and should be used for reference only.

Liability

EdgeTech has made every effort to document the 4205 system in this manual wholly and accurately. However, EdgeTech assumes no liability for errors or any damages resulting from using this manual or the equipment it documents. EdgeTech reserves the right to upgrade this equipment's features and make changes to this manual without notice.

Revision History

REVISION	DESCRIPTION	DATE	APPROVAL
A	Release to Production	2/19/2019	TS
B	Content Updates	7/19/2019	TS
C	Drawing and Text Updates	8/23/2019	TS
D	701-DL, Towfish Pictures, Drawing, Format Updates	6/22/2020	PO
E	AHRS usage instructions added. Content updates.	12/07/2020	PO
F	Digital Link and Product Updates	06/01/2021	DMD
G	Product Photos, Macrium, and Text Updates	02/26/2024	PO
H	V-Wing Drawing Update	10/22/2024	DMD
J	Beacon Update	10/25/2025	BS

WARRANTY STATEMENT

All equipment manufactured by EdgeTech is warranted against defective components and workmanship for a period of one year after shipment. Warranty repair will be done by EdgeTech free of charge.

Shipping costs are to be borne by the customer. Malfunction due to improper use is not covered in the warranty, and EdgeTech disclaims any liability for consequential damage resulting from defects in the equipment's performance. No product is warranted as being fit for a particular purpose, and there is no warranty of merchantability. This warranty applies only if:

- i. The items are used solely under the operating conditions and in the manner recommended in the Seller's instruction manual, specifications, or other literature.
- ii. The items have not been misused or abused in any manner, nor have repairs been attempted thereon without the approval of EdgeTech Customer Service.
- iii. Written notice of the failure within the warranty period is forwarded to the Seller, and the directions received for properly identifying items returned under warranty are followed.
- iv. The return notice authorizes the Seller to examine and disassemble returned products to the extent the Seller deems necessary to ascertain the cause for failure.

The warranties expressed herein are exclusive. There are no other warranties, either expressed or implied, beyond those set forth herein. The Seller does not assume any other obligation or liability in connection with the sale or use of said products. Any product or service repaired under this warranty shall be warranted for the remaining portion of the original warranty period only.

Equipment not manufactured by EdgeTech is supported only to the extent of the original manufacturer's warranties.

SOFTWARE SERVICE OVERVIEW

EdgeTech provides software services free of charge. This software agreement does not address customer-specified modifications or enhancements. These services may be ordered separately. Furthermore, EdgeTech software upgrades are meant for the sole use of EdgeTech customers. Any reproduction of EdgeTech-supplied software or file sharing is strictly prohibited.

Software Updates and Enhancements

EdgeTech customers can download new software releases with all modifications and enhancements from the [EDGE TECH WEBSITE](#). Should major software issues occur, they will be reported directly to the customer. New software releases consist of the following:

- Software enhancements that are not on the price list
- Software updates and bug fixes
- Product integration
- Documentation updates to online help
- Tests for compatibility with other modules

Software patches consist of software that has undergone the following:

- Minor software enhancements
- Software fixes and changes

EdgeTech customers are entitled to contact [CUSTOMER SERVICE](#) by telephone, facsimile, or e-mail to report a difficulty, discuss a problem, or receive advice on the best way to perform a task. When contacted, EdgeTech Customer Service will do the following:

- Respond within 24 hours via Telephone, Facsimile, and E-mail Support
- Immediately attend to serious problems affecting operations
- Attempt to find an immediate workaround

RETURNED MATERIAL AUTHORIZATION

Before returning any equipment to EdgeTech, a Returned Material Authorization (RMA) Number must be obtained from **CUSTOMER SERVICE**.

RMA Purpose

The RMA Number identifies returned equipment when it arrives at our receiving dock and enables tracking while at our facility. Refer to the RMA number on all documentation and correspondences.

All returned materials must be shipped prepaid. Freight collect shipments will not be accepted. All equipment should be adequately insured for shipping, but equipment belonging to EdgeTech must be insured for full value.

If there is more than one item per consignment, include a packing list with the shipment. An invoice can double as a packing slip only when the contents are clearly numbered and identified on the invoice.

CAUTION! Never attempt to ship a Portable Topside in its Pelican® or SKB® case alone. Although rugged, these cases are not intended to be used as shipping containers, and the delicate internal components could be damaged. Shipping in this manner will void any warranties.

NOTE: All shipping charges shall be the customer's responsibility unless under warranty, as EdgeTech will pay for return shipping.

NOTE: For International Shipments valued over \$1000, the following Shipper's oath must be sent with the invoice.

Shipper's Oath:

"I, _____, declare that the articles herein specified are the growth, produce, or manufacture of the United States; that they were exported from the United States from the port of _____, on or about _____; that they are returned without having been advanced in value or improved in condition by any process of manufacture or any other means; and that no drawback, or allowance has been paid or admitted hereof."

Signed _____

CUSTOMER SERVICE

Customer service personnel at EdgeTech are always eager to hear from you regarding our products. Your feedback is welcome and a valuable source of information that we use to improve products. Therefore, we encourage you to contact **CUSTOMER SERVICE** to offer any suggestions or to request technical support:

NOTE: Please have your system Model and Serial Number available when contacting Customer Service.

E-mail: service@EdgeTech.com

Mail: 4 Little Brook Road
West Wareham, MA 02576

Telephone: (508) 291-0057

Fax: (508) 291-2491

**24-Hour Emergency
Technical Support Line:** (508) 942-8043

For more information, please go to WWW.EDGETECH.COM.

COMPANY BACKGROUND

EdgeTech (formerly EG&G Marine Instruments) traces its underwater data acquisition and processing history back to 1966. EdgeTech has designed, developed, and manufactured products, instruments, and systems — for the acquisition of underwater data, including marine, estuarine, and coastal applications — for over 50 years.

EdgeTech responds to the needs of the scientific, naval, and offshore communities by providing industry-leading equipment — such as sub-bottom profilers, side-scan sonar, acoustic releases, USBL positioning systems, and bathymetric systems — that have become standards in the industry.

EdgeTech consistently anticipates and responds to future needs with an active research and development program. Current efforts are focused on adopting new cutting-edge acoustic technology.

TABLE OF CONTENTS

ATTENTION – READ THIS FIRST!	1-3
Warnings, Cautions, and Notes.....	1-3
HARDWARE VARIATIONS AND COMPATIBILITY	1-4
ABOUT THIS DOCUMENT	1-5
Purpose of this Manual.....	1-5
Liability.....	1-5
Revision History	1-5
WARRANTY STATEMENT	1-6
SOFTWARE SERVICE OVERVIEW	1-7
Software Updates and Enhancements.....	1-7
RETURNED MATERIAL AUTHORIZATION	1-8
RMA Purpose	1-8
CUSTOMER SERVICE	1-9
COMPANY BACKGROUND	1-10
TABLE OF CONTENTS	1-11
LIST OF FIGURES	1-15
LIST OF TABLES	1-17
1.0 OVERVIEW	1-17
1.1 4205 Side Scan Sonar System Applications	1-19
1.2 Main System Components.....	1-20
1.2.1 Topside Processor.....	1-20
1.2.2 Towfish.....	1-21
1.2.3 Tow Cables.....	1-23
1.3 Optional Equipment	1-23
1.3.1 SBG AHRS	1-23
1.3.2 Depressor Wing	1-23
1.3.3 Magnetometer Interface	1-24
1.3.4 Acoustic Tracking System	1-24
1.3.5 Pressure Sensor	1-27
2.0 SPECIFICATIONS	2-28
2.1 4205 Sonar Performance Specifications.....	2-28

2.2	4205 Towfish Specifications	2-29
2.3	Kevlar Tow Cable Specifications	2-30
2.4	Armored Tow Cable Specifications.....	2-30
2.5	Mechanical Drawings.....	2-31
2.5.1	4205 Towfish Drawings.....	2-31
2.5.2	Electronic Bottle and Connection Drawings	2-34
2.5.3	Cable Drawings	2-39
3.0	TECHNICAL DESCRIPTIONS.....	3-43
3.1	Towfish Technical Description.....	3-43
3.1.1.1	4205 Tri-Frequency Towfish	3-45
3.1.1.2	4205-MPMT & Single Pulse Towfish.....	3-45
4.0	SYSTEM SETUP.....	4-49
4.1	Unpacking and Inspection	4-49
4.2	Power Requirements	4-49
4.2.1	Use of an Uninterrupted Power Supply.....	4-49
4.2.2	Magnetometer Power	4-50
4.2.3	Change to a Non-US Power Plug.....	4-50
4.3	Navigation Interface	4-50
4.4	Topside Processor Placement.....	4-51
4.5	TCP/IP Address Settings.....	4-51
4.6	Connecting the System Components	4-52
4.6.1	Connect and Attach the Tow Cable to the Towfish.....	4-53
4.6.2	Installing a Depressor Wing and Connecting the Tow Cable.....	4-54
4.6.3	Connecting to the Topside.....	4-54
4.6.3.1	Connecting to the Starmux IV DL.....	4-54
4.6.3.2	Connecting to the 4205 Rack Mount with Starmux IV DL.....	4-55
4.6.3.3	Connecting to the 701-DL.....	4-55
4.6.3.4	Connecting to the 4205 Rack Mount with 701-DL	4-55
5.0	SYSTEM ACTIVATION, TEST, AND DEPLOYMENT.....	5-57
5.1	Activating the Topside	5-57
5.1.1	Activating a Starmux IV System	5-57
5.1.2	Activating a 701-DL System	5-57
5.2	SBG AHRS Usage	5-58

5.3	Performing Pre-deployment Checks.....	5-59
5.4	Towfish Deployment.....	5-63
5.5	Towfish Recovery.....	5-65
6.0	MAINTENANCE	6-67
6.1	Inspect and Clean the Towfish and Cable after Use.....	6-67
6.2	Inspect and Clean the Underwater Connectors	6-67
6.3	Storage.....	6-67
6.4	Recommended Spares	6-67
7.0	TROUBLESHOOTING.....	7-68
7.1	Disassembling and Reassembling the Towfish	7-68
7.1.1	Disassembling the 4205 Towfish:	7-68
7.1.2	Assembling the Tow Vehicle	7-72
7.2	Standard AHRS Calibration	7-72
7.3	Starmux IV / 701-DL Troubleshooting	7-73
7.4	4205 Rack Mount Troubleshooting Guide.....	7-74
7.5	Towfish Troubleshooting Guide	7-74
7.5.1	Required Equipment.....	7-75
7.5.2	4205 vehicle	7-75
7.5.2.1	No Sonar Data.....	7-75
7.5.2.2	Reported Errors	7-76
7.5.2.3	Other Checks	7-76
7.5.3	Transmission Verification	7-76
7.5.4	Topside Power Unit	7-76
7.5.5	Command and Data Link.....	7-77
7.5.6	Data Link	7-77
7.6	Tow Cable Troubleshooting.....	7-78
7.6.1.1	Shorted Wire.....	7-78
7.6.1.2	Open Wire.....	7-79
7.6.1.3	Insulation Resistance Breakdown.....	7-79
7.6.1.4	Damaged Tow Cable Connector	7-80
A.0	4205 KITS	7-81
A.1	4205 MPMT Spare Kits	7-81
A.2	4205 Tri-Frequency Spare Kits	7-82

A.3 Tool Kit.....7-84

LIST OF FIGURES

Figure 1-1: 4205 Towfish.....	1-18
Figure 1-2: 4205 Tri-Frequency Discover, Target Logger, and Coverage Mapper Displays	1-19
Figure 1-3: Starmux IV Rackmount with Keyboard, Trackball and LCD Monitor	1-20
Figure 1-4: 701-DL Rackmount.....	1-20
Figure 1-5: Starmux IV in SKB Case	1-21
Figure 1-6: 701-DL in 2U-SKB Case.....	1-21
Figure 1-7: 4205 Towfish Side View	1-22
Figure 1-8: 4205 Towfish Forward View	1-22
Figure 1-9: 4205 Towfish Aft View	1-22
Figure 1-10: Kevlar Tow Cable	1-23
Figure 1-11: 4205 Beacon Interconnect Overview Diagram (PN 0027167).....	1-25
Figure 1-12: Assy Sub Cable Y-Splice 4205 to Sonardyne WSM6 Mini Responder/Mag (PN 0024690) ..	1-26
Figure 2-1: 4205 Towfish ICD	2-31
Figure 2-2: Optional 4205 2-Foot Depressor Wing pg.1	2-32
Figure 2-3: Optional 4205 2-Foot Depressor Wing pg.2	2-33
Figure 2-4: 4205 MPMT Towfish Endcap Connections	2-34
Figure 2-5: 4205 Tri-Frequency Endcap Connections	2-35
Figure 2-6: Tow Cable Connections	2-36
Figure 2-7: 4205 MPMT and Tri-Frequency Tow Cable Connections with Pinouts	2-37
Figure 2-8: 4205 MPMT and Tri-Frequency ROV Tow Cable Connections with Pinouts.	2-38
Figure 2-9: Kevlar 50m Reinforced Tow Cable.....	2-39
Figure 2-10: Kevlar 150m Reinforced Tow Cable.....	2-40
Figure 2-11: Armored 250m Tow Cable	2-41
Figure 2-12: Armored 500m Tow Cable.....	2-42
Figure 3-1: 4205 SP/MPMT Towfish Diagram.....	3-44
Figure 3-2: Typical 4205 System Diagram using 1500m tow Cable	3-46
Figure 3-3: 4205 Rack-Mounted System with the Directional Multi-Beacon Transponder/Responder used with the EdgeTech USBL BATS	3-47
Figure 3-4: Network Interface Diagram	3-48
Figure 4-1: Discover Serial Port Configuration.....	4-50

Figure 4-2: Windows Manual IP Properties Window.....	4-51
Figure 4-3: 4205 Towfish with Armored Tow Cable	4-53
Figure 5-1: Discover 4205 MPMT Sonar Activation	5-59
Figure 5-2: Discover 4205 Tri-Frequency Sonar Activation	5-60
Figure 5-3: 4205 MPMT Shortcut High and Low-Frequency Range Fields and N (Gain) and T (TVG) Buttons	5-60
Figure 5-4: 4205 MPMT Towfish Control Range Fields.....	5-60
Figure 5-5: Tri Frequency Range Entry Fields.....	5-61
Figure 5-6: Tri-Frequency Gain and TVG Buttons	5-61
Figure 5-7: 4205 MPMT Shortcut Toolbar Record Button Location	5-61
Figure 5-8: 4205 MPMT Recorder Play and Stop Buttons	5-61
Figure 5-9: 4205 Tri-Frequency Record and Stop Buttons.....	5-61
Figure 5-10: 4205 MPMT Disk Tab Playback Controls Play Button.....	5-62
Figure 5-11: 4205 MPMT Shortcut Toolbar Play Button.....	5-62
Figure 5-12: 4205 Tri-Frequency Shortcut Toolbar and Disk Tab Playback Controls Play Button	5-62
Figure 5-13: Heading, Pitch, and Roll Datablock Locations on Top Line of Main Status Line Display	5-62
Figure 5-14: 4205 Towfish Deployment.....	5-63
Figure 5-15: 4205 MPMT Bottom Track Tab.....	5-64
Figure 5-16: 4205 Tri-Frequency Bottom Track Tab	5-65
Figure 7-1: Tailfin Removal	7-68
Figure 7-2: Aft Endcap Cable Disconnection.....	7-69
Figure 7-3: Side Seal Screw and Washer	7-69
Figure 7-4: Nylon Retaining Line Removal	7-70
Figure 7-5: Nose Cone Removal.....	7-70
Figure 7-6: Forward Endcap Cable Disconnections.....	7-71
Figure 7-7: Aft Endcap Grip Handle Installation	7-71
Figure 7-8: Electronics Chassis Removal From Towfish Housing	7-72
Figure 7-9: SockBlast on Towfish Side.....	7-77
Figure 7-10: Sockblast Client on Topside Computer.....	7-78

LIST OF TABLES

Table 1-1: 4205 Towfish Sonar Options	1-21
Table 1-2: 4205 Options Bulkhead MCBH8F	1-24
Table 2-1: 4205 Sonar Performance Specifications	2-28
Table 2-2: 4205 Towfish Specifications	2-29
Table 2-3: Kevlar Tow Cable Specifications	2-30
Table 2-4: Armored Tow Cable Specifications	2-30
Table 4-1: AC Power Wiring Wire Colors for Conversion	4-50
Table 4-2: EdgeTech Default Reserved IP Numbers By System and Component	4-52
Table 7-1: Troubleshooting Table	7-73
Table 7-2: Reported Errors	7-76
Table 7-3: 4205 MPMT 100-400 kHz Spare Kit	7-81
Table 7-4: 4205 MP 230-530 kHz Spare Kit	7-81
Table 7-5: 4205 MP 230-850 kHz Spare Kit	7-82
Table 7-6: 4205 Tri-Frequency 120/410/850 Spare Kit	7-82
Table 7-7: 4205 Tri-Frequency 120/540/850 Spares Kit	7-83
Table 7-8: 4205 Tool Kit	7-84

1.0 OVERVIEW

The EdgeTech 4205 Side Scan Sonar System is a proven and versatile side scan sonar system suitable for most shallow and deep water survey applications. The 4205 is available in either a tri-frequency side-scan sonar configuration or a motion-tolerant and multi-pulse (MTMP) configuration. All 4205 systems consist of a topside processor with a computer and a hydrodynamic stainless-steel towfish. Topside processor



Figure 1-1: 4205 Towfish

choices are a portable or rack-mounted unit with an optional Edgetech-provided rugged laptop or rack-mounted desktop computer. EdgeTech Discover 4205 Software is included with every system, providing system control, monitoring, data processing, and acquisition. 4205 system power and connections support a wide range of additional sensors. Towfish and target positioning have been improved by integrating a more accurate heading sensor and providing the option for a USBL beacon.

The tri-frequency variant frequency options are 120/410/850 kHz or 230/540/850 kHz. The system allows for the simultaneous operation of two of three sonar frequencies with on-demand frequency changes that provide an excellent and efficient search and identification process. Long-range operations are achieved by selecting the lower frequency combination (230/540kHz). Then, on-demand, the system can be changed to the higher frequency combination (540/850kHz) for a high-resolution survey.

The 4205 Motion Tolerant configuration with Multi-Pulse (MPMT) variant allows surveyors to operate at faster survey speeds in more adverse weather conditions while still obtaining high-quality underwater imagery. This configuration can also be operated in a single pulse (SP) high-definition mode (HDM) for operations requiring a highly detailed seafloor view. Sonar frequency options are 120/410 kHz, 230/540 kHz, or 230/850 kHz. The two frequencies are transmitted simultaneously in both the SP and MP configurations. In the MP configuration, the sonar doubles the repetition rate. This allows for increased tow speeds of up to 9.6 knots while meeting the NOAA and IHO-44S Shallow Water Survey Specification of three pings on a 1-meter cubed target at 100 meters.

The 4205 sonar system utilizes EdgeTech's CHIRP technology to provide crisp, high-resolution imagery at ranges up to 50% greater than non-CHIRP systems, allowing customers to cover larger areas and save money on costly surveys. In all configurations, the frequencies are transmitted as linearly-swept, high-

energy acoustic pulses. The received echoes are processed into high Signal-to-Noise Ratio (SNR) images that can be directly displayed as shades of gray or one of many varying color palettes on a computer monitor.

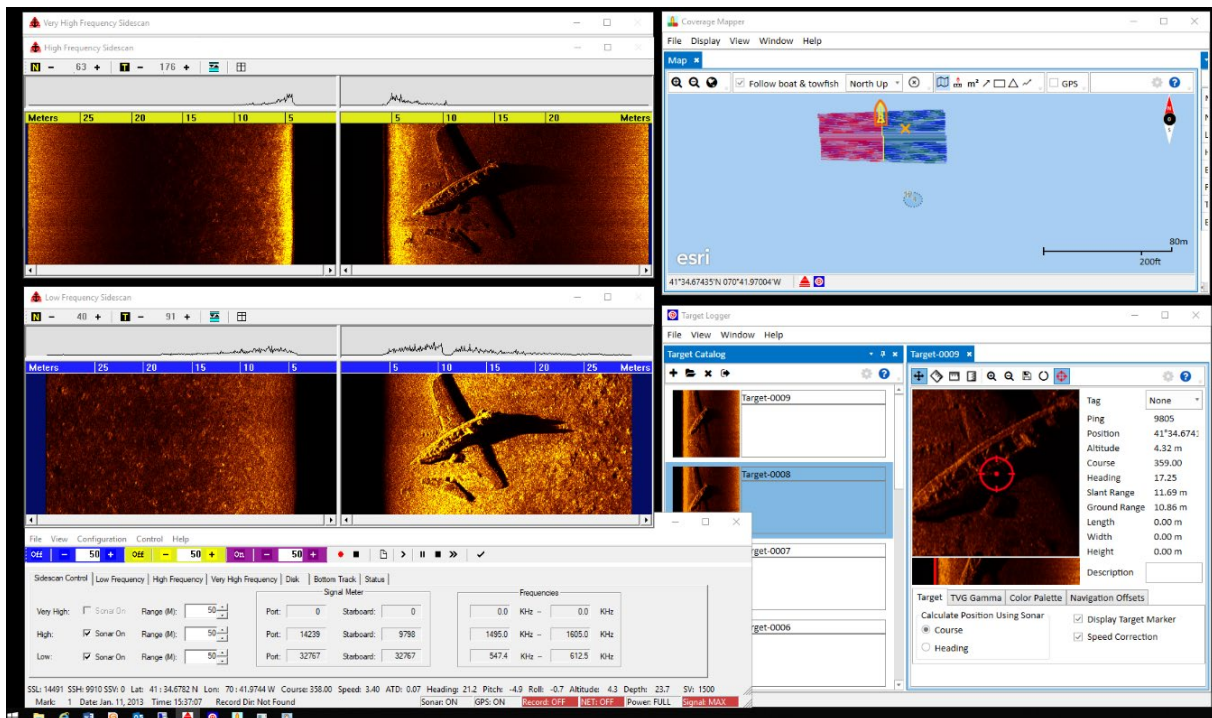

Figure 1-2: 4205 Tri-Frequency Discover, Target Logger, and Coverage Mapper Displays

The 4205 has a variety of features, including:

- Tri-frequency side scan sonar
- Motion tolerant mode
- Improved target positioning
- Crisp, high-resolution CHIRP images
- Increased Towfish power to support a broader range of additional third-party sensors
- Single-pulse high-definition mode

1.1 4205 Side Scan Sonar System Applications

The 4205 Side Scan Sonar System has many potential applications, including:

- Cable & pipeline surveys
- Geological/geophysical surveys
- Mine countermeasures (MCM)
- Geohazard surveys
- Channel clearance
- Search and recovery
- Archeological surveys

1.2 Main System Components

The 4205 Side Scan Sonar System is made up of 3 main components:

- Choice of 701-DL or Starmux IV Topside processor. Each is available in a rackmount version with an EdgeTech-configured computer.
- 4205 Towfish (Tri-Frequency or MPMT variant)
- Tow cable (Available up to 6000 meters in length)

Contact [CUSTOMER SERVICE](#) for questions about cable types and lengths.

1.2.1 Topside Processor

Each of the 4205 Topside Processor options provides downlink telemetry to the towfish for sonar control. They also receive uplink side scan data, sensor data, and status information from the towfish for processing, storage, and display. Each topside processor interfaces with a towfish over a 10/100BaseT connection, using asynchronous digital subscriber line (ADSL) modems.

There are four 4205 Topside processor configuration options:

- **Starmux IV DL** [with or without Laptop]
- **4205 Starmux IV Rack Mount**
 - Starmux IV and 2U Computer inside Case
 - Keyboard / Trackball
 - LCD Monitor
- **701-Digital Link DL** [with or without a Laptop]
- **4205 701-DL Rack**
 - 701-D-Link and 2U Computer inside a 6U Hardigg Case
 - Keyboard / Trackball
 - LCD Monitor

Starmux IV and 701-DL Rack Mount options come with a preconfigured EdgeTech 2U Windows 10 computer with Discover Installed. If just the digital link is purchased, users can install Discover on their computers or buy an EdgeTech Windows 10 laptop with Discover installed.

Detailed information can be found in both the [701-DL AND STARMUX IV HARDWARE MANUALS](#).



Figure 1-3: Starmux IV Rackmount with Keyboard, Trackball and LCD Monitor



Figure 1-4: 701-DL Rackmount



Figure 1-5: Starmux IV in SKB Case



Figure 1-6: 701-DL in 2U-SKB Case

1.2.2 Towfish

The 4205 Towfish) comes in standard Tow or ROV/Tow Interface with Multi-Pulse or Tri Frequency Sonar configurations (TABLE 1-1).

4205 TRI-FREQUENCY	4205 MPMT
120/410/850 kHz	120-410 kHz
230/540/850 kHz	230-540 kHz
	230-850 kHz

Table 1-1: 4205 Towfish Sonar Options

The towfish assembly consists of the sonar transducer arrays and the electronics required to transmit and receive sonar signals, receive the downlink commands from the topside processor, and provide the uplink side-scan data, sensor data, and status information to the topside processor. See the **TOWFISH TECHNICAL DESCRIPTION** section of this manual for details on towfish system configurations.

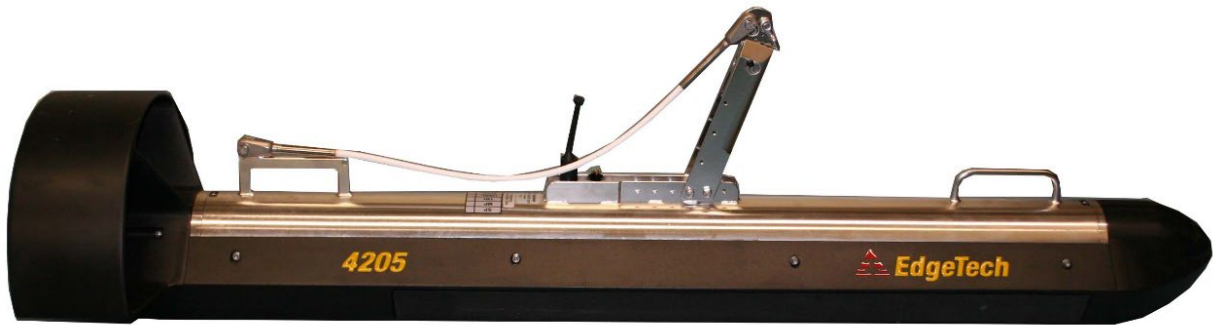

Figure 1-7: 4205 Towfish Side View



Figure 1-8: 4205 Towfish Forward View



Figure 1-9: 4205 Towfish Aft View

1.2.3 Tow Cables

The tow cables are used to both connect and tow the towfish. They are available in the customer's choice of Kevlar-reinforced, shown in **FIGURE 1-10**, or armored-style cables. Depending on customer requirements, all cable types can be terminated at both ends or just at the towfish end.

Both cable types include a single conductor and a shield. They also include an MCIL6F female wet-pluggable connector on the towfish end and either an MCIL4M male wet-pluggable connector on the topside processor end or an open termination for direct connection to the slip rings of a winch. A cable grip is included to attach the tow cable to the towfish towing arm.



Figure 1-10: Kevlar Tow Cable

1.3 Optional Equipment

The following optional equipment can be installed and/or powered on 4205 systems via a separate options connector:

- SBG AHRS (Attitude and Heading Reference System)
- Depressor Wing
- Magnetometer Interface
- Acoustic tracking system
- Pressure sensor
- Responder

NOTE: The option connector provides a maximum of 27 VDC \pm 4% at 2.6 amps.

1.3.1 SBG AHRS

The 4205 Towfish has a standard compass that provides heading, pitch, and roll. The SBG AHRS (Attitude and Heading Reference System) option offers a lightweight sensor with a MEMS-based Inertial Measurement Unit (IMU) that integrates three gyroscopes, three magnetometers, and three accelerometers. The AHRS utilizes an extended Kalman filter (EKF) to provide accurate orientation data in static and dynamic conditions. See the **SBG AHRS USAGE** section of this manual for more details on this altitude and heading reference system.

1.3.2 Depressor Wing

The EdgeTech Depressor Wing (see **FIGURE 2-2** and **FIGURE 2-3**) allows the towfish to be towed at greater depths and faster speeds without increasing the tow cable's length in the water. The depressor wing attaches to the top of any 4205 Towfish and exerts a downward force, pushing it deeper as it moves through the water. The wing angle is adjustable to 0°, 5°, or 10°, depending on the desired dive angle.

Optionally available trim tabs can be adjusted for fine-tuning its performance. A safety cable is attached to prevent loss of the wing should it become snagged and detached from its mount. Additional information and diagrams are found in the 4205 Depressor Wing Addendum (PN 0021771).

1.3.3 Magnetometer Interface

Several third-party Magnetometers are compatible with EdgeTech's optional magnetometer interface. See the 4205 Magnetometer Interface Option Documentation (PN 0021770) for more information. See [FIGURE 2-7](#) and [FIGURE 2-8](#) for information on the magnetometer wiring connection.

1.3.4 Acoustic Tracking System

A USBL acoustic tracking system can be used to provide continuous tracking of the 4205 towfish. A (CFE) responder and bracket is installed on the tow cable, near the towfish, and a ship-mounted hydrophone and deck unit are used to receive and process position data.

The output trigger from an external tracking system deck unit can be used as the input trigger to the topside processor. The topside processor modulates the digital input trigger and transmits this to the towfish via the same data/power cable. The towfish demodulates the trigger and outputs a TTL pulse to drive the responder.

The 4205's 08 position female bulkhead connector, depicted in [FIGURE 1-11](#), is the interface for the Beacon as well as the Magnetometer (if required). The pin outs for the options bulkhead are shown [FIGURE 2-7](#), [FIGURE 2-8](#), and [TABLE 1-2](#) below. When a Beacon and Magnetometer are used together, a WYE cable ([FIGURE 1-12](#)) is connected to the Options bulkhead.

NOTE: The 4205 only provides a current limited “trickle charge” to the devices. The user should only provide devices with fully charged batteries to ensure proper performance.

POSITION	FUNCTION
1	+27 vdc
2	0 vdc
3	TX
4	RX
5	RS 232 RETURN
6	Trigger
7	+27 vdc
8	0 vdc

Table 1-2: 4205 Options Bulkhead MCBH8F

UNLESS AS MAY BE OTHERWISE PROVIDED BY CONTRACT, THESE DRAWINGS AND SPECIFICATIONS ARE THE PROPERTY OF "EDGETECH" AND ARE ISSUED IN STRICT CONFIDENCE AND SHALL NOT BE REPRODUCED, COPIED OR USED AS THE BASIS FOR THE MANUFACTURE OR SALE OF APPARATUS WITHOUT PERMISSION. COPYRIGHT © 2018 EDGETECH INC.

REVISIONS			
REV	DESCRIPTION	DATE	APPROVED
A	Initial Release	02/14/25	PO

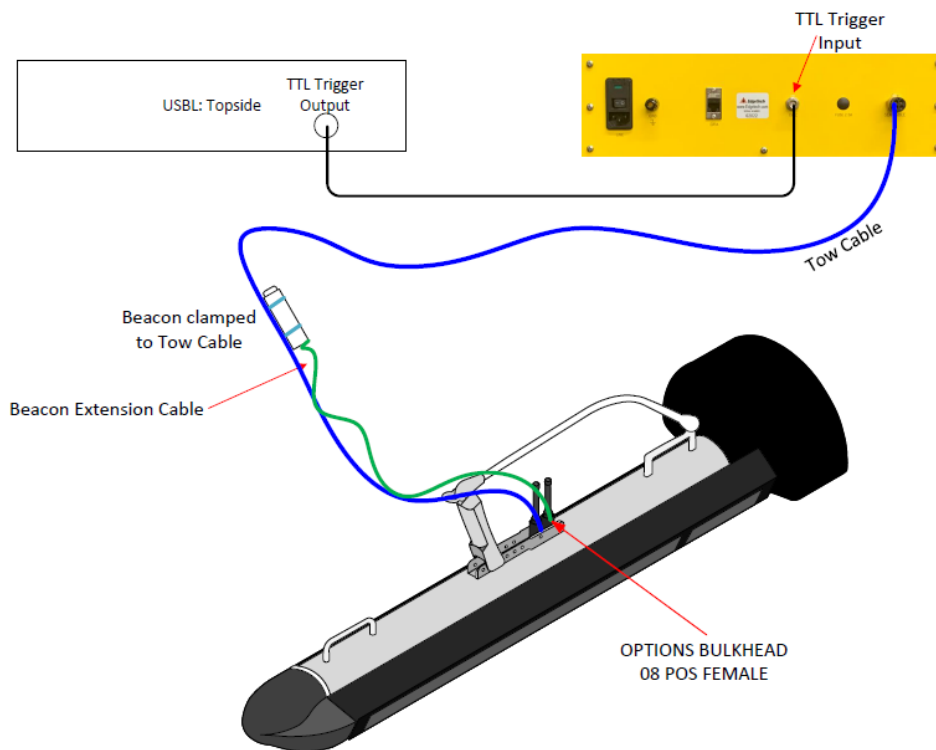

NOTES

1) A WYE cable (such as 0024690) is connected to the Options Bulkhead when the Beacon is used in conjunction with the Magnetometer.

APPROVALS	DATE	 <small>4 Little Brook Road West Wareham, MA 02576 Tel: (508) 291-0057 / Fax: 291-2491 Email: info@EdgeTech.com</small>		
DRAWN: PO	2/14/2025			
CHECKED: DMD	02/16/25	DOC 4205 BEACON INTERCONNECT OVERVIEW		
ENG:				
ISSUED		PROFILE NAME	DRAWING NO.	Rev
SYSTEM	4205	SCALE	0027167	

Figure 1-11: 4205 Beacon Interconnect Overview Diagram (PN 0027167)

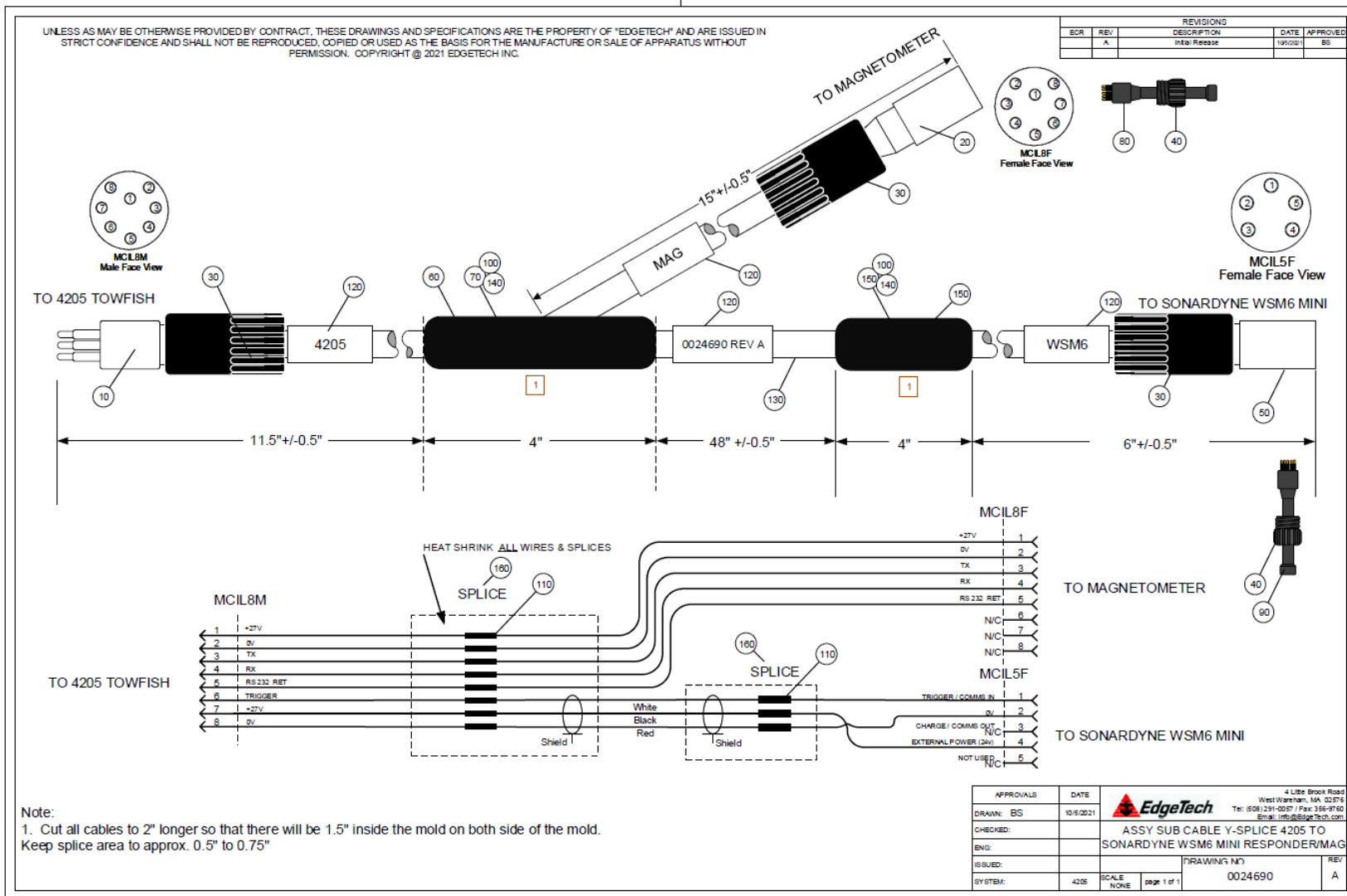

Figure 1-12: Assy Sub Cable Y-Splice 4205 to Sonardyne WSM6 Mini Responder/Mag (PN 0024690)

Many third-party responder beacons are on the market, and properly interfacing them with the 4205 could be challenging. Please contact [CUSTOMER SERVICE](#) for guidance in selecting and/or interfacing a third-party beacon with the 4205 towfish.

1.3.5 Pressure Sensor

A stainless-steel pressure sensor can be installed in the towfish to provide real-time depth data. This pressure sensor is designed for continuous use in a corrosive liquid environment and is available in a 3000-psi pressure rating.

2.0 SPECIFICATIONS

The standard EdgeTech 4205 Side Scan Sonar System specifications are described below. Please refer to the provided addendum or contact **EDGETECH CUSTOMER SERVICE** for configuration-specific information for detailed information regarding custom systems.

Specifications of 4205 Side Scan Sonar System Main Components:

- **4205 SONAR PERFORMANCE SPECIFICATIONS**
- **4205 TOPSIDE SPECIFICATIONS**
- **4205 TOPSIDE SPECIFICATIONS**

NOTE: All specifications are subject to change without notice.

2.1 4205 Sonar Performance Specifications

SONAR SPECIFICATIONS	4205	4205 MULTI-PULSE/MOTION TOLERANT (MP/MT) AND HIGH DEFINITION MODE		
	TRI-FREQUENCY	MP/MT		HDM
Frequency	120/410/850 kHz 230/540/850 kHz	120/410 kHz, 230/540 kHz 230/850 kHz		
Operating Range (meters/side)	120 kHz: 600m, 230 kHz: 350m, 410 kHz: 200m, 540 kHz: 150m, 850 kHz: 90m			
Horizontal Beam Width (2-way)	TRI-FREQUENCY	MP/MT		HDM
	120 kHz: 0.7°	120kHz: 0.95°		0.7°
	230 kHz: 0.4°	230kHz: 0.63°		0.44°
	410 kHz: 0.28°	410kHz: 0.38°		0.28°
	540 kHz: 0.26°	540kHz: 0.35°		0.26°
Resolution Along Track	850 kHz: 0.23°	850kHz: 0.30°		0.23°
	120 kHz: 2.4m @ 200m	120kHz: 3.3m @ 200m		2.4m @ 200m
	230 kHz: 1.2m @ 150m	230kHz: 1.7m @ 150m		1.2m @ 150m
	410 kHz: 0.5m @ 100m	410kHz: 0.7m @ 100m		0.5m @ 100m
	540 kHz: 0.45m @ 100m	540kHz: 0.6m @ 100m		0.45m @ 100m
Resolution Across Track	850 kHz: 0.20m @ 50m	850kHz: 0.26m @ 50m		0.20m @ 50m
	120kHz 8cm; 230kHz 3cm; 410kHz 2 cm; 540kHz 1.5cm; 850kHz 1cm			
Vertical Beam Width	50° (+/- 25°)			
Depression Angle	Tilted down 25° relative to horizontal			

Table 2-1: 4205 Sonar Performance Specifications

2.2 4205 Towfish Specifications

SPECIFICATION	VALUES
Size:	Diameter 12 cm (4.8 in) Length 140 cm (55 in)
Weight in air:	52 kg (115 lb)
Weight in saltwater:	36 kg (80 lb)
Construction:	Stainless steel
Maximum tow cable length:	6000 m (19,680 ft) Contact EdgeTech for cable type vs. length.
Depth rating:	2000 m (6560 ft)
Tow cable type:	Coaxial
Shear pin type:	8 mm (5/16 in.) Delrin rod
Shear force:	544 kg (1200 lb)
Modulation:	Chirp frequency-modulated pulse with amplitude and phase weighting
Digital link:	4 Mbits/sec (typical), 4 channels of side-scan data plus sensor data
Maximum towing speed while meeting NOAA and IHO-44S specifications of 3 pings on a 1-meter cubed target at 100 meters (4205-SP):	4.8 knots
Maximum towing speed while meeting NOAA and IHO-44S specifications of 3 pings on a 1-meter cubed target at 100 meters (4205-MP):	<u>HDM</u> 4.8 knots <u>HSM</u> 9.6 knots
Standard Sensors	Heading, pitch & roll
Maximum safe towing speed:	12 knots
Operating temperature:	0–45°C (32–113°F)
Storage temperature:	-20–60°C (-4–140°F)
Heading accuracy:	1.5° RMS
Pitch and roll accuracy:	0.1° (nominal)
Optional sensor port:	(1) Serial – RS 232C, Bi-directional 28VDC +/-4% @ 2.6 amps
Options:	Pressure Sensor, Magnetometer, Integrated USBL Acoustic Tracking System, Built-in Responder Nose, Depressor, Power Loss Pinger, and Custom Sensors

Table 2-2: 4205 Towfish Specifications

2.3 Kevlar Tow Cable Specifications

SPECIFICATION	VALUE
Construction	Polyurethane, Kevlar, PVC, Tinned Copper
Weight In Air	30 kg / 305 m (66 lbs / 1000 ft)
Weight in Seawater	7.8 kg / 305 m (17.3 lbs / 1000 ft)
Specific Gravity	1.45 g/cc
Strength Member:	Aramid Braid Minimum Break 1134 kg (2500 lbs)
Minimum Bend Radius (Dynamic)	25.4 cm (10.0 in)
Capacitance	30 pF/ft nominal
Impedance	50 Ω
Velocity of Propagation	66% nominal

Table 2-3: Kevlar Tow Cable Specifications

2.4 Armored Tow Cable Specifications

SPECIFICATION	VALUE
Construction	Steel Armored
Grip Type	PMI (wet end)
Weight In Air	469 kg/km (315 lb/kft)
Weight in Seawater	397 kg/km (255 lb/kft)
Specific Gravity	5.4
Breaking Strength	71.2 kN (16,000 lbf)
Maximum Working Load	17.8 kN (4,000 lbf)
Minimum Bend Radius	23 cm (9 in)
Voltage Rating	1,900 VDC
DC Resistance	9.8 Ω /km (9.8 Ω /kft) 6.9 Ω /km (6.9 Ω /kft)

Table 2-4: Armored Tow Cable Specifications

2.5 Mechanical Drawings

Mechanical Drawing of the Towfish and tow cable connections are provided on the following pages:

2.5.1 4205 Towfish Drawings

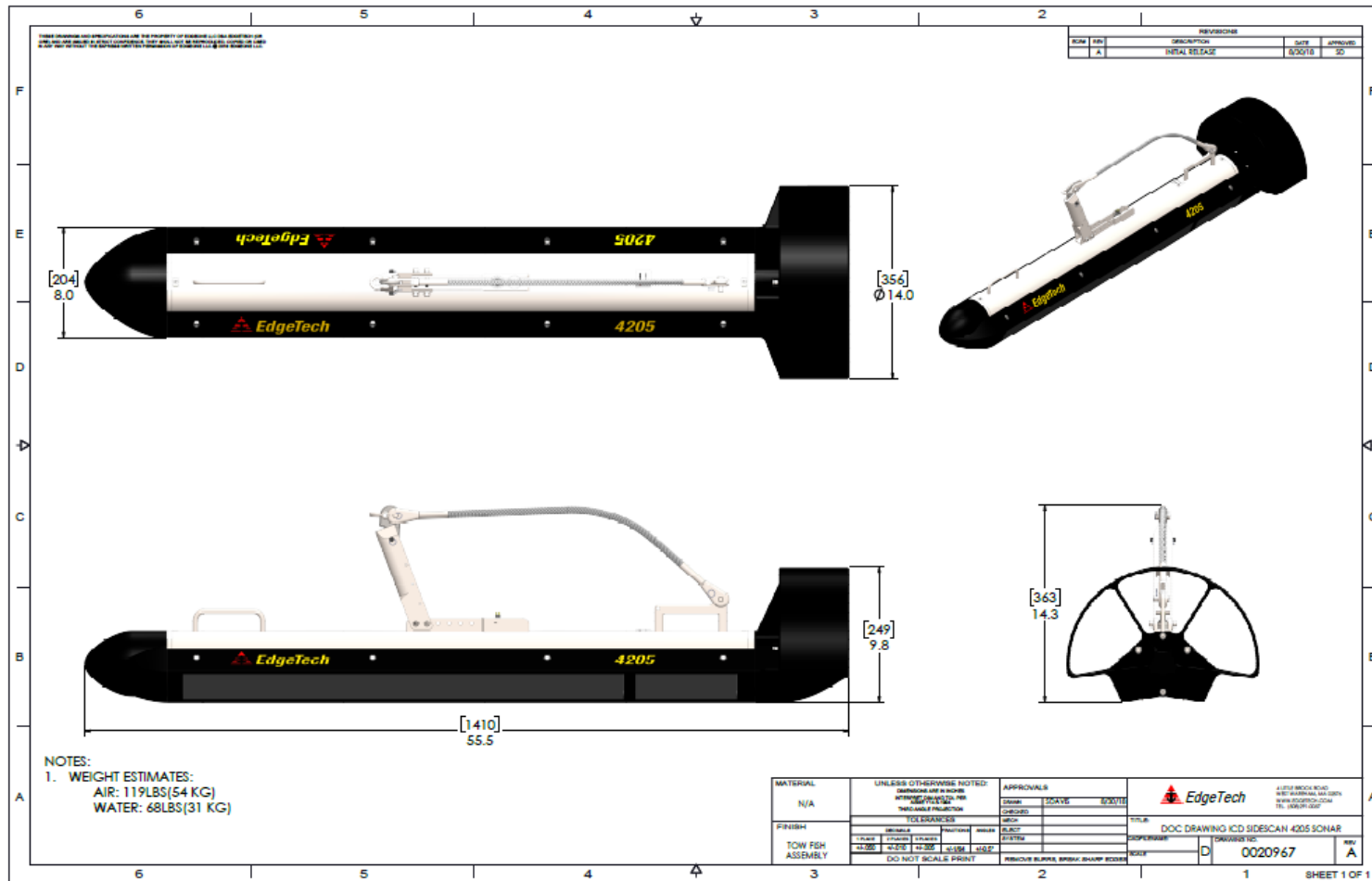

Figure 2-1: 4205 Towfish ICD

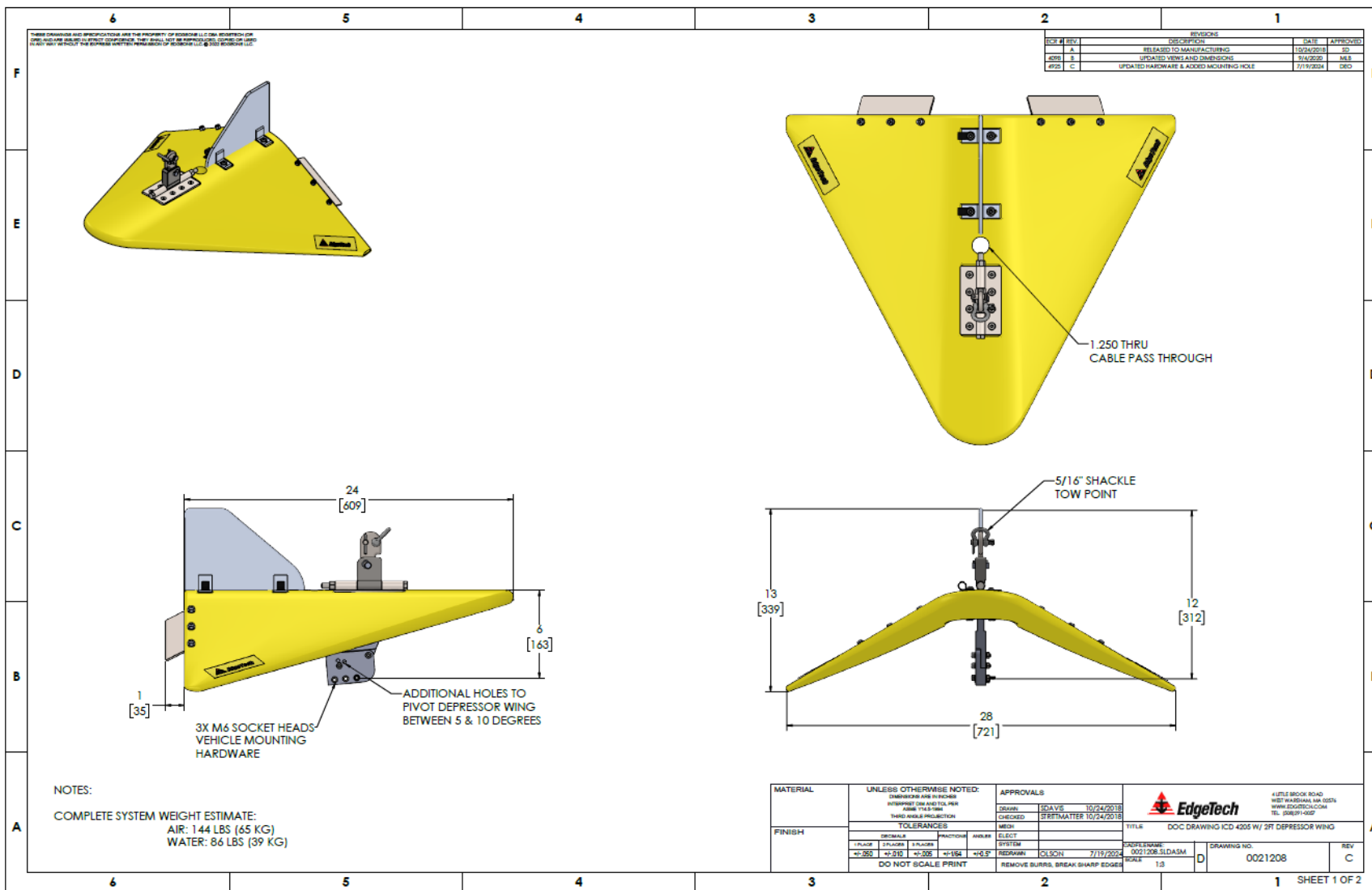

Figure 2-2: Optional 4205 2-Foot Depressor Wing pg.1

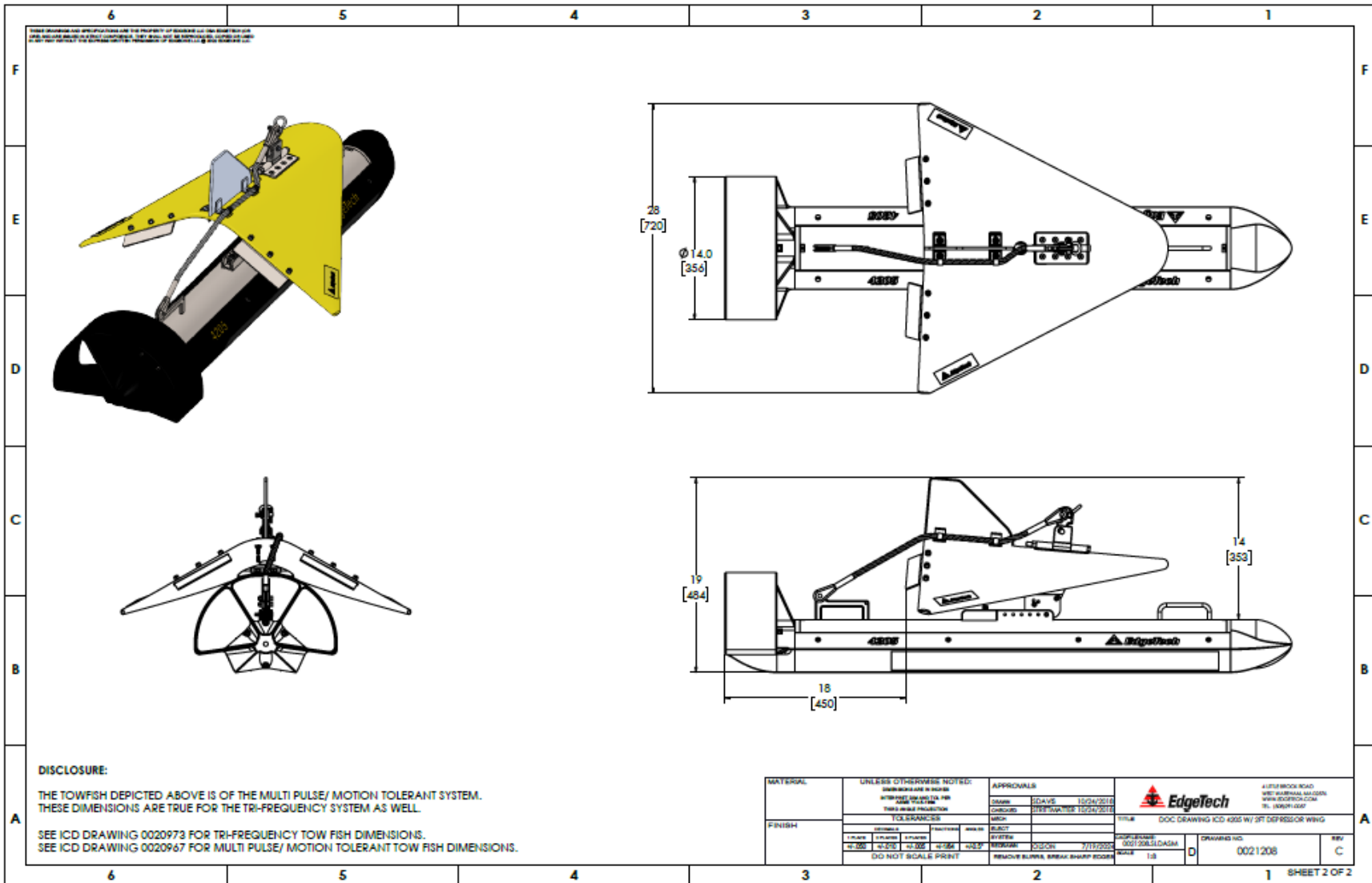

Figure 2-3: Optional 4205 2-Foot Depressor Wing pg.2

2.5.2 Electronic Bottle and Connection Drawings

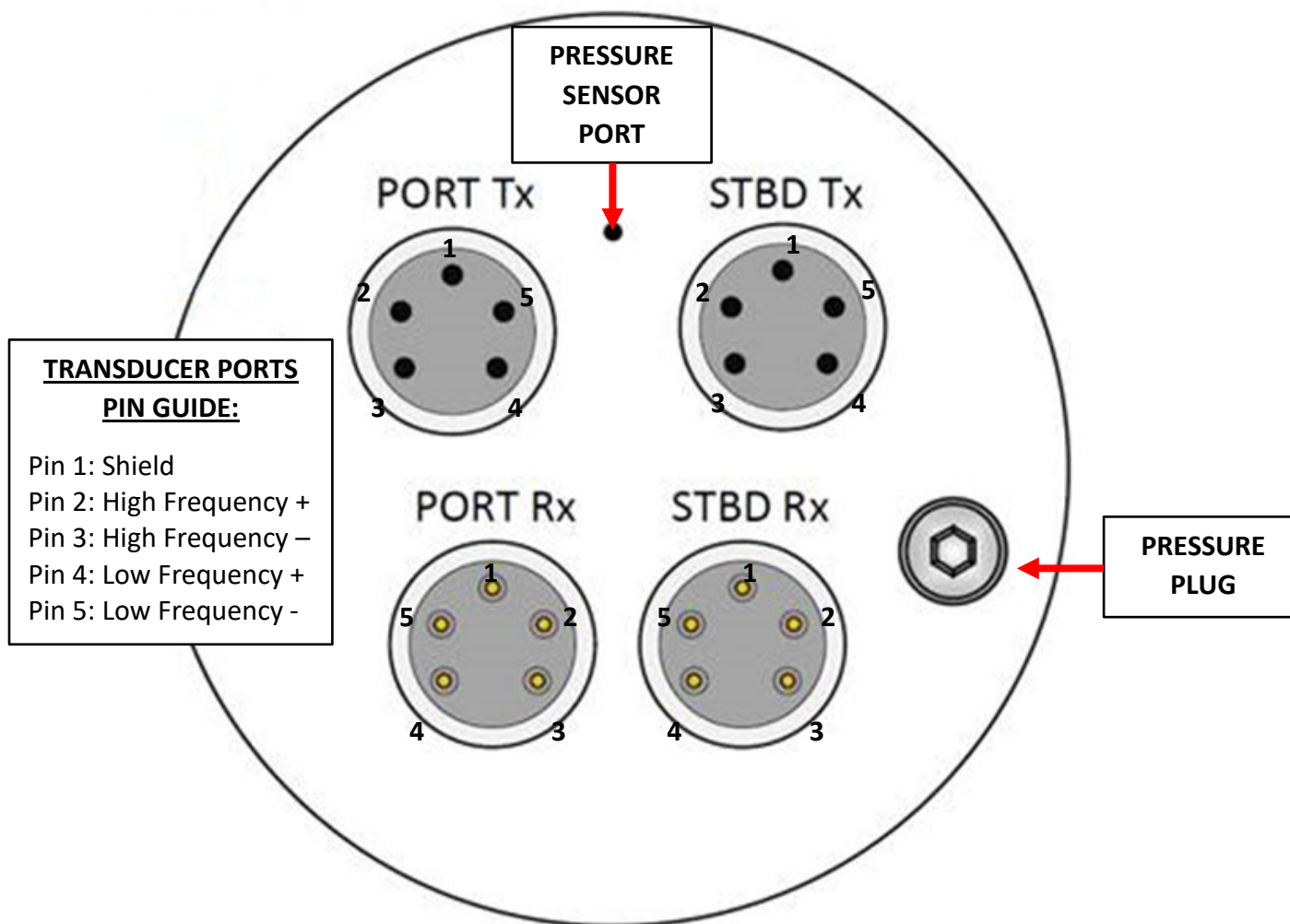

Figure 2-4: 4205 MPMT Towfish Endcap Connections

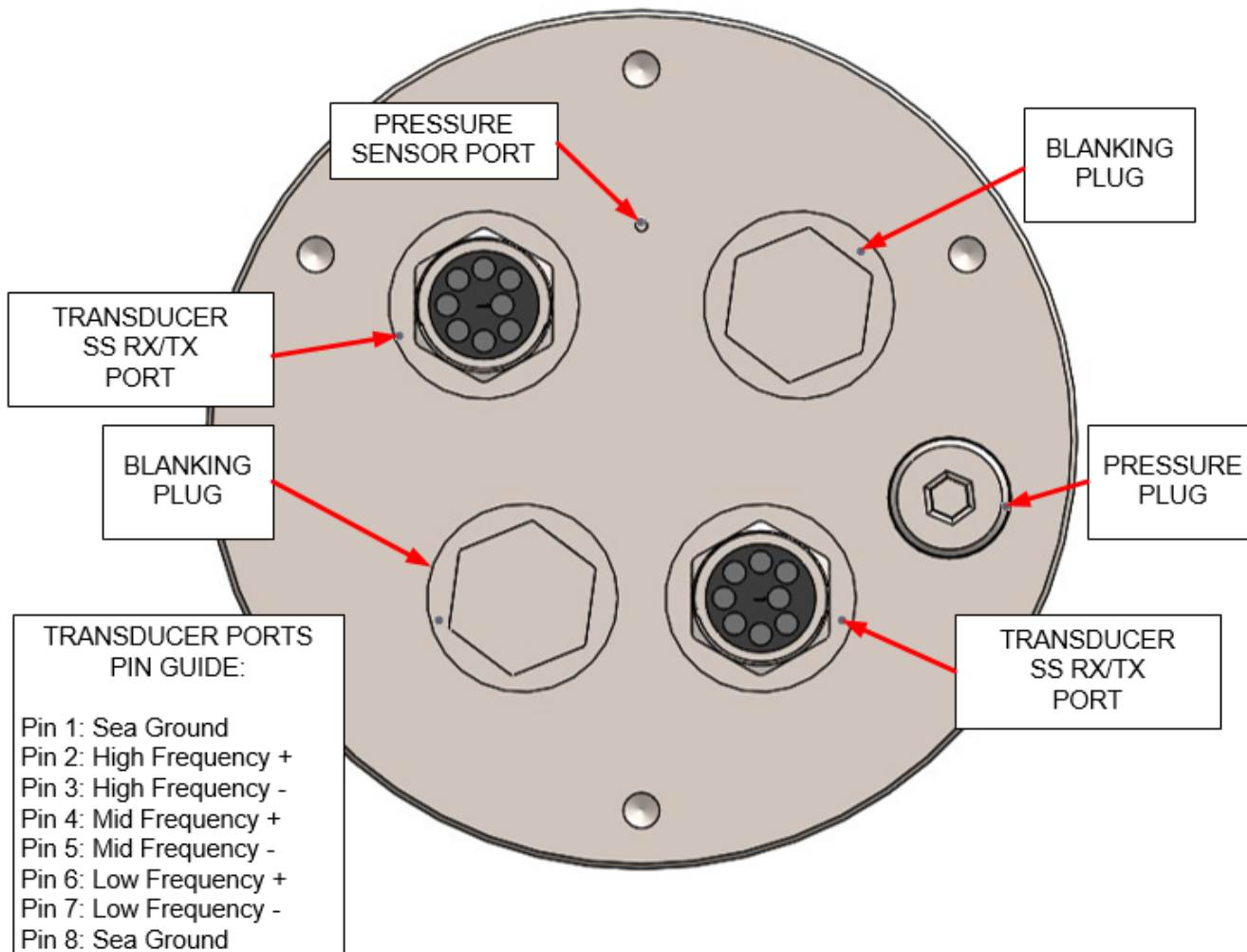

Figure 2-5: 4205 Tri-Frequency Endcap Connections

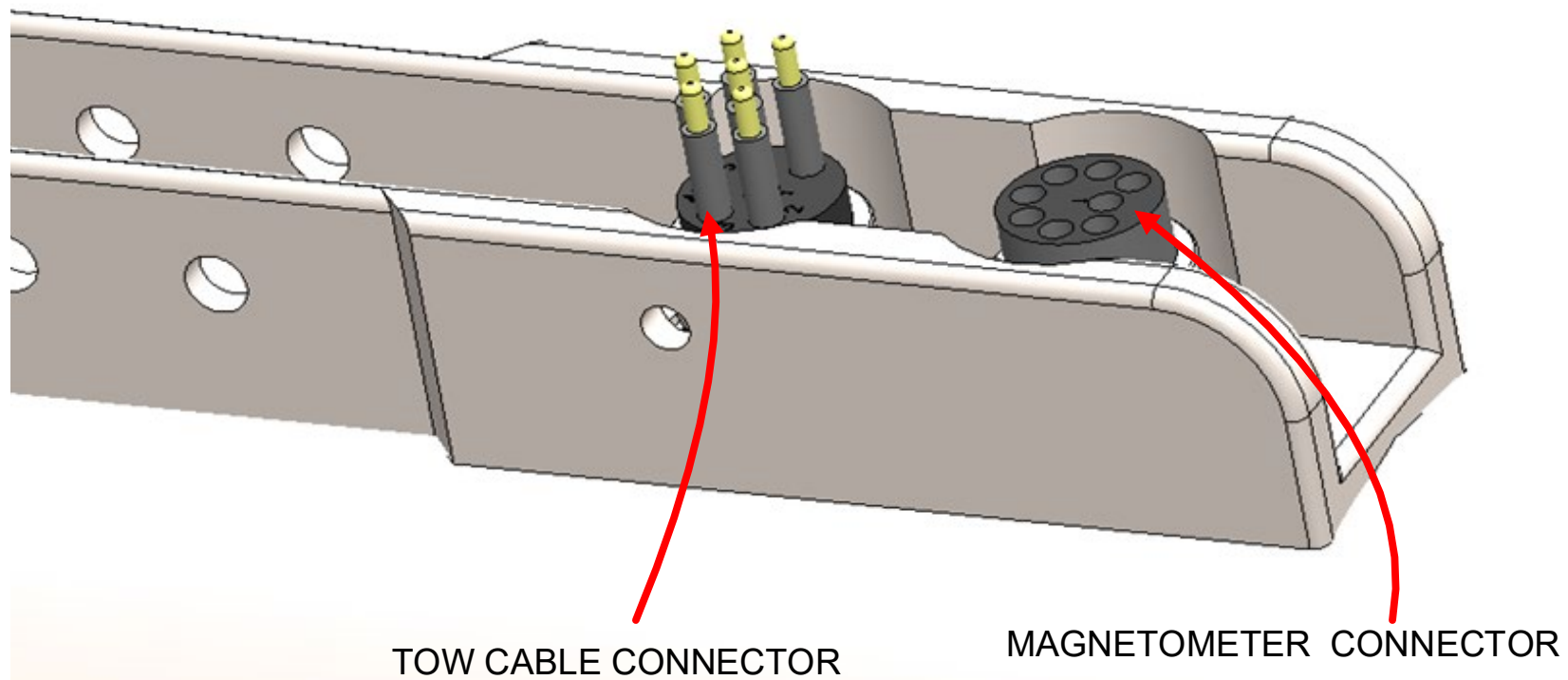
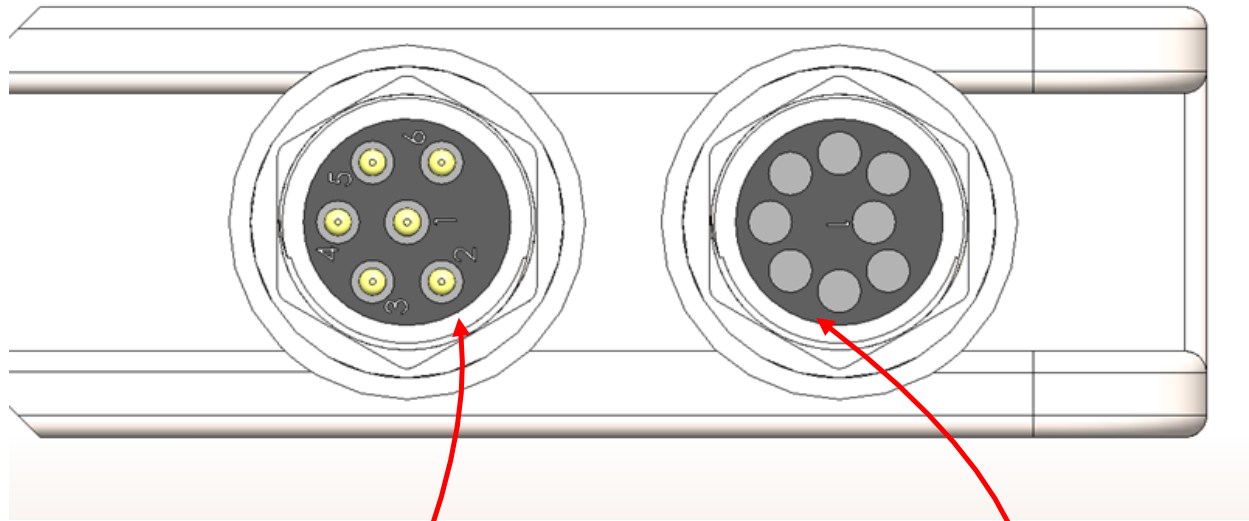

Figure 2-6: Tow Cable Connections



TOW CABLE CONNECTIONS:

Pin 1 : 0 VDC
 PIN 2 : +375VDC+Telemetry
 PIN 3 : Not Connected
 PIN 4 : Not Connected
 PIN 5 : Not Connected
 PIN 6 : Not Connected

MAGNETOMETER CONNECTIONS:

Pin 1 : 27 VDC
 PIN 2 : Return/RS-232 GND
 PIN 3 : SONAR RS232 TX to Mag
 PIN 4 : SONAR RS232 RX from Mag
 PIN 5 : Return/RS-232 GND
 PIN 6 : TRIG-MAG
 PIN 7 : 27 VDC
 PIN 8 : GND

Figure 2-7: 4205 MPMT and Tri-Frequency Tow Cable Connections with Pinouts

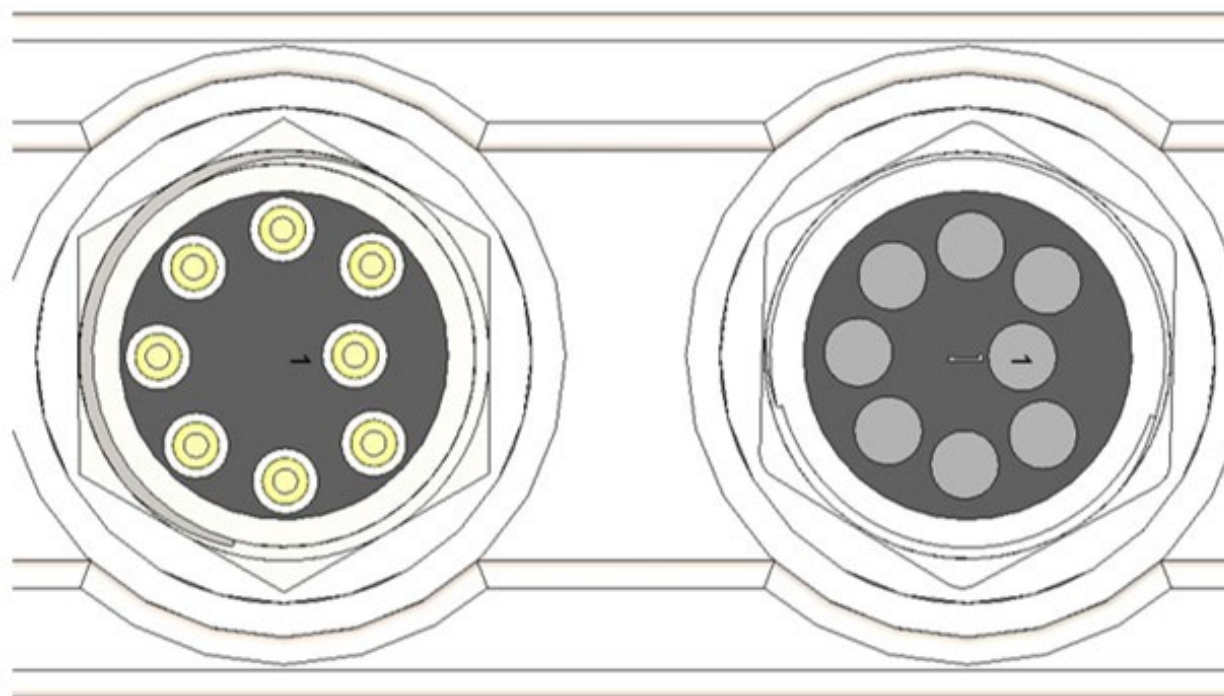

TOW/ROV CONNECTIONS

PIN 1 : 400 VDC RTN
 PIN 2 : 400 VDC +Telemetry
 PIN 3 : 48 VDC RTN
 PIN 4 : 48 VDC
 PIN 5 : Ethernet TX+
 PIN 6 : Ethernet TX-
 PIN 7 : Ethernet RX+
 PIN 8 : Ethernet RX-

MAGNETOMETER CONNECTIONS

PIN 1 : 27 VDC
 PIN 2 : RETURN/RS-232 GND
 PIN 3 : Side Scan TX to Mag (RS-232)
 PIN 4 : Side Scan RX to Mag (RS-232)
 PIN 5 : RETURN/RS-232 GND
 PIN 6 : TRIGGER MAG
 PIN 7 : 27 VDC
 PIN 8 : GND

Figure 2-8: 4205 MPMT and Tri-Frequency ROV Tow Cable Connections with Pinouts.

2.5.3 Cable Drawings

Diagrams of the optionally available cables are as follows:

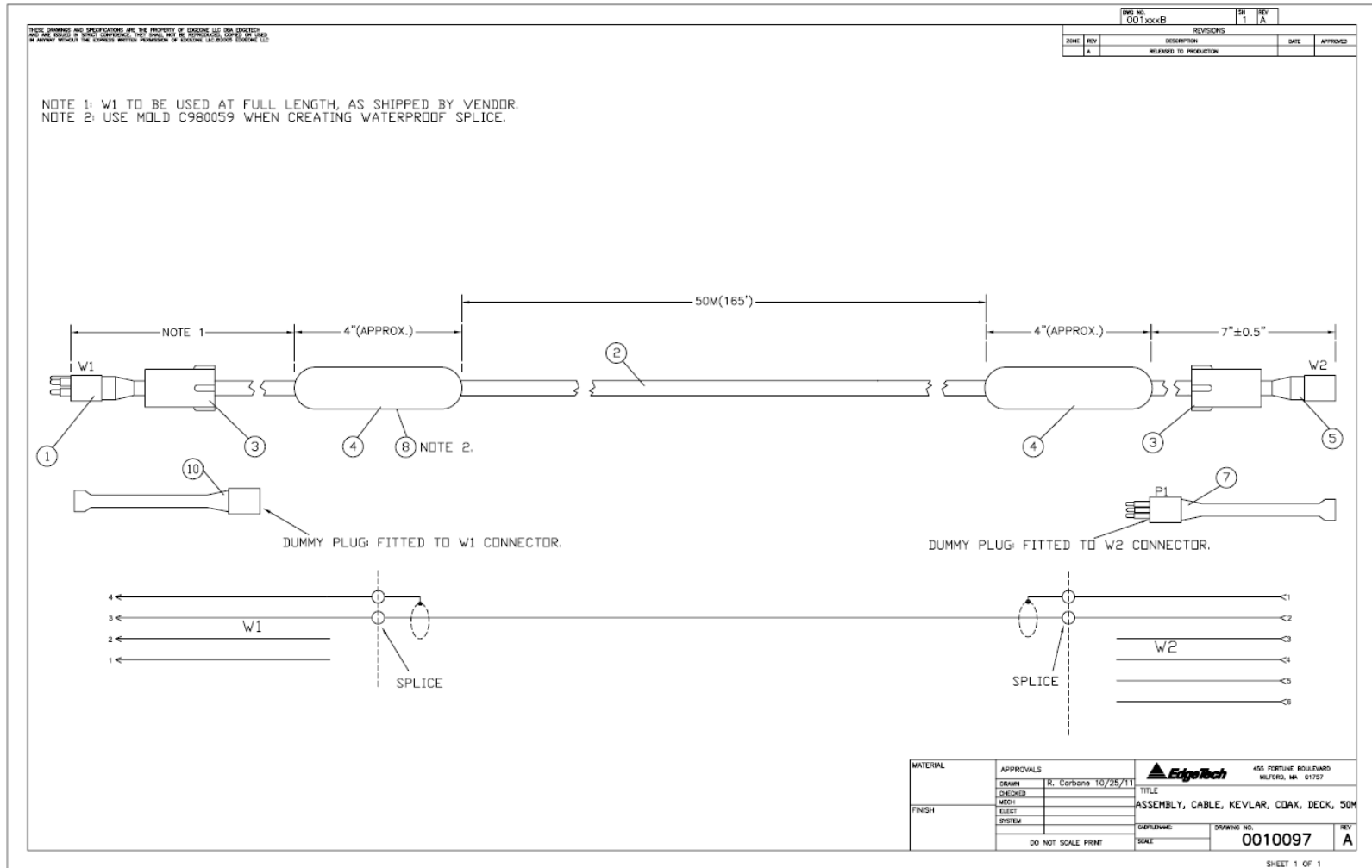

Figure 2-9: Kevlar 50m Reinforced Tow Cable

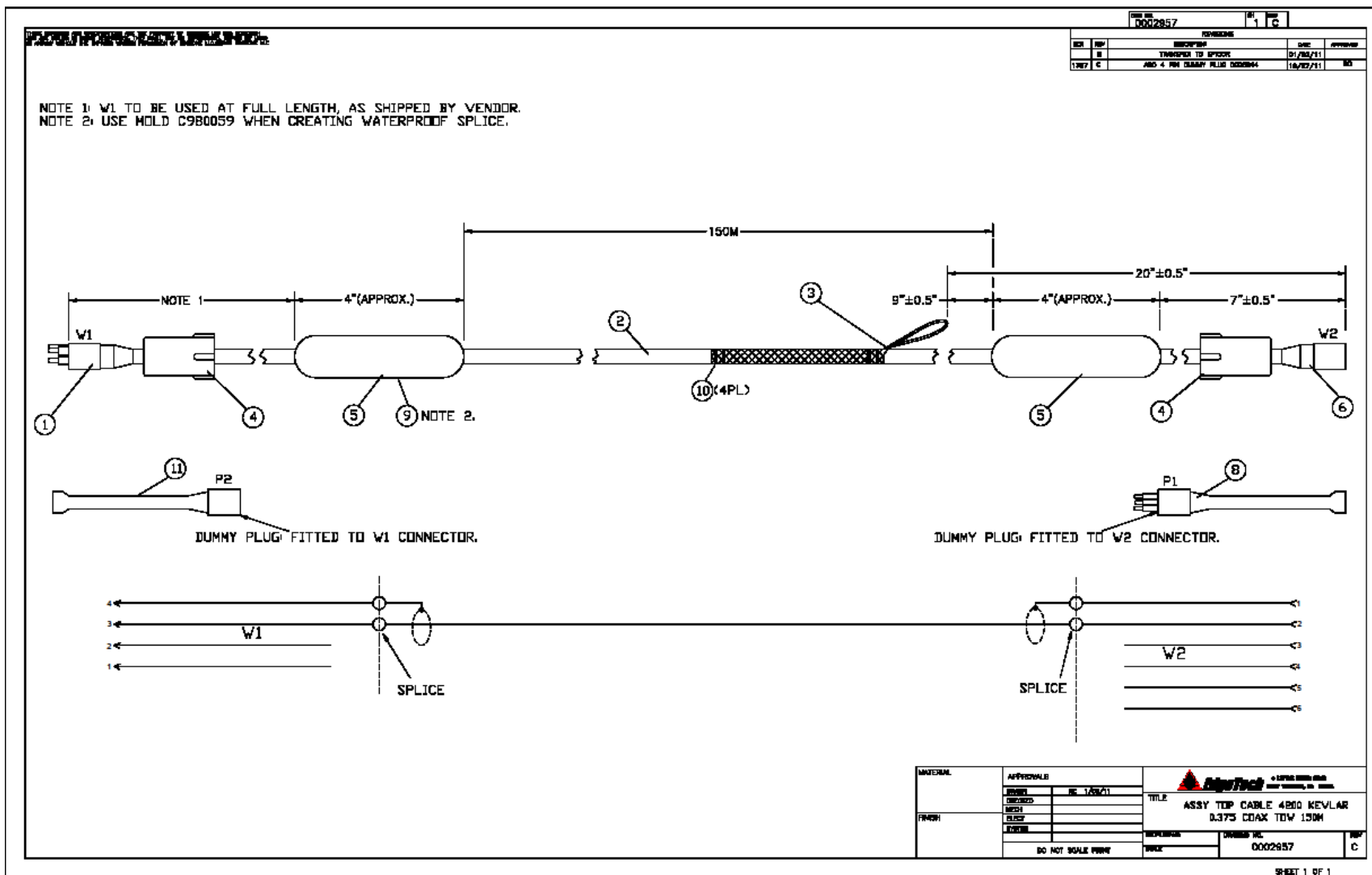

Figure 2-10: Kevlar 150m Reinforced Tow Cable

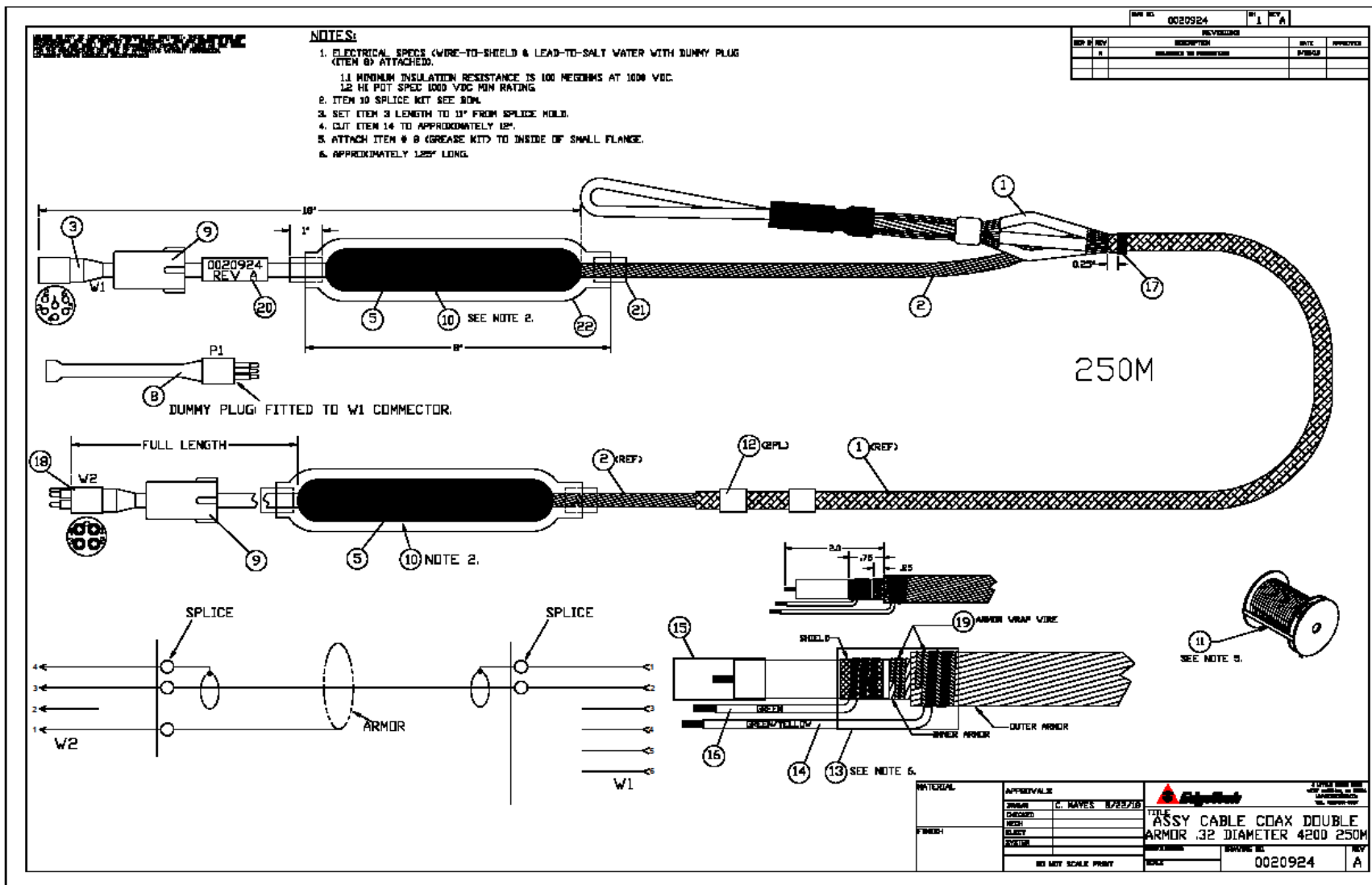

Figure 2-11: Armored 250m Tow Cable

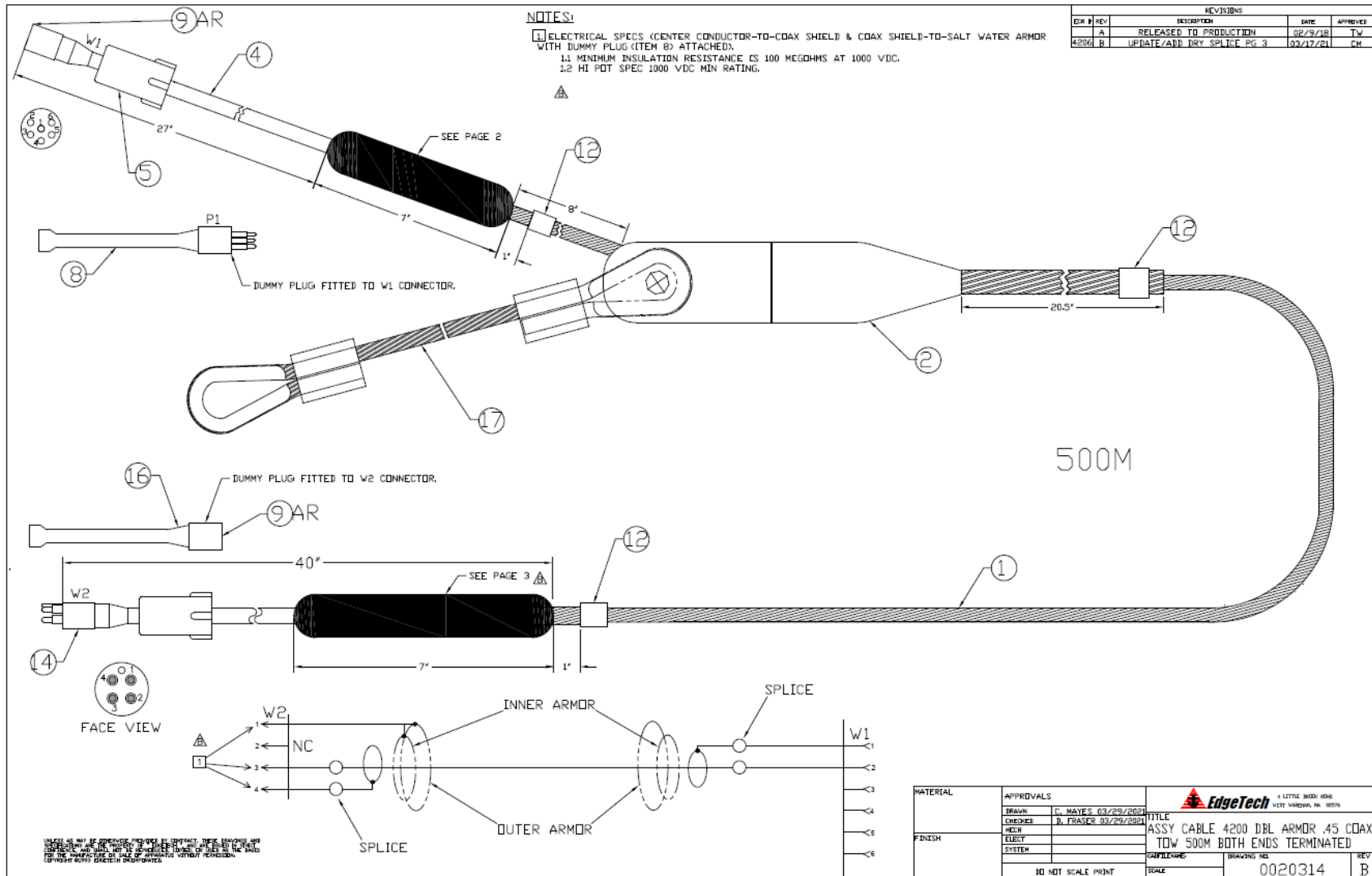

Figure 2-12: Armored 500m Tow Cable

3.0 TECHNICAL DESCRIPTIONS

Before attempting to operate the 4205 System, EdgeTech recommends becoming acquainted with how its various components work and interact. This section provides technical descriptions, diagrams, and photographs to help you better understand the inner workings of your highly specialized sonar system.

3.1 Towfish Technical Description

The towfish contains the sonar transducer arrays and electronics required to transmit and receive sonar signals, receive the downlink commands from the topside processor, and provide the uplink side-scan data, sensor data, and status information to the topside processor.

The electronics are contained inside a single sealed housing to which the transducer arrays are attached and connectors accessible. Double O-ring endcaps seal the forward and aft end of the vehicle. Bulkhead connectors for connecting to the transducer arrays are in the aft endcap. The 6-pin main I/O connector and 8-pin option connector are located on top of the towfish. The towfish housing also includes two convenient carrying handles.

The towfish interfaces with the topside processor over a 10/100BaseT Ethernet connection using an asynchronous digital subscriber line (ADSL) modem in both the towfish and the topside electronics.

All 4205 Towfish configurations have a stabilizer tail and a nose weighted for hydrodynamic balance. A towing arm is rigidly mounted to a tow point on the top of the towfish housing adjacent to the tow cable and option connectors. The tow cable safety grip attaches to a tow key on the tow arm, as shown in **FIGURE 3-1**. Should you need to reposition the towing arm forward or aft to adjust the balance of the towfish, additional mounting holes are provided on the tow point. The towing arm also includes a safety release mechanism, which causes the shear pin to release the tow key if the towfish hits an obstruction or becomes snagged. Should this happen, the towfish will rotate, nose down, and a safety cable attached from the tow point to the stern of the towfish will pull the towfish, stern first, over the obstruction or through the snag.

Both 4205 Single-Pulse (SP)/Multi-Pulse/Motion Tolerant (MP/MT) and Tri-Frequency configurations provide simultaneous dual-frequency operation and are designed to accommodate the integration of optional sensors. All configurations provide excellent signal-to-noise performance, resulting in high-quality data reliably transmitted digitally over coaxial cables up to 6,000m in length.

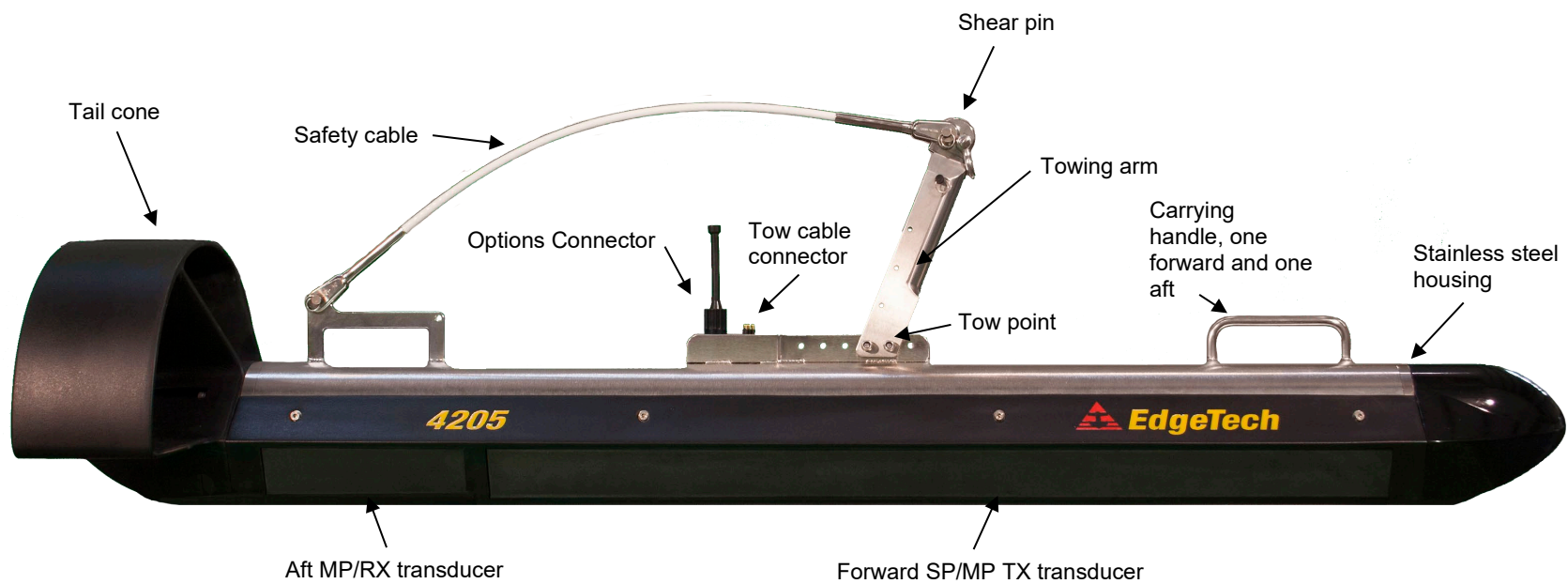

Figure 3-1: 4205 SP/MPMT Towfish Diagram

3.1.1.1 4205 Tri-Frequency Towfish

EdgeTech offers a tri-frequency side scan sonar (120/410/850 kHz or 230/540/850 kHz), allowing surveyors to operate any two frequencies simultaneously. Long-range operations can be achieved with a selection of 120/410 kHz combination, and then, on-demand, the 4205 can be changed to operate at 410/850kHz for a higher resolution survey. Target positioning is improved by integrating a more accurate heading sensor (AHRS) that can be coupled with an optional USBL.

Operation in single pulse (SP) mode and a maximum towfish speed of 4.8 knots will ensure compliance with the NOAA and IHO-44S Shallow Water Survey Specification of three pings on a 1-meter cubed target with the range set at 100 meters.

3.1.1.2 4205-MPMT & Single Pulse Towfish

The 4205-MPMT system enables higher survey speeds while maintaining full-bottom along-track coverage. The towfish includes identical port and starboard forward-mounted TX/RX and aft-mounted RX-only transducer arrays. It is available with a choice of 120/410 kHz, 230/540 kHz, or 230/850 kHz dual linear CHIRP operating frequencies.

The towfish operates in either Multi-Pulse/Motion Tolerant (MP/MT) mode or Single Pulse (High Definition) mode. In MP/MT mode, the forward transducer array is used as a transmitter, and the aft array is used as a receiver. The resulting transducer beam pattern shape compensates for motion in the tow vehicle yaw axis while facilitating high-speed operation by transmitting and receiving multiple pulses in the water.

In SP mode, the system operates in a high definition mode (HDM) where only the forward transducer can transmit and receive acoustic energy. A higher-resolution image is obtained in this mode at the expense of lower tow speeds (for full bottom coverage). Operation in SP mode has a maximum towfish speed of 4.8 knots to ensure compliance with the NOAA and IHO-44S Shallow Water Survey Specification of three pings on a 1-meter cubed target with the range set at 100 meters.

Compared to the SP system, the MP configuration allows two pulses to be in the water during each ping cycle instead of just one. This allows the conventional tow speed to be doubled so the same SP coverage can be completed in half the time. Conversely, twice the data density of an SP configuration can be achieved at conventional survey speeds with an MP-fitted system due to the two-pulse generation within the same range window. These benefits of MP technology translate into better target detection and classification capabilities. Standard CHIRP technology makes the SP and MP configurations far less expensive than similar-performing high-speed multi-beam systems.

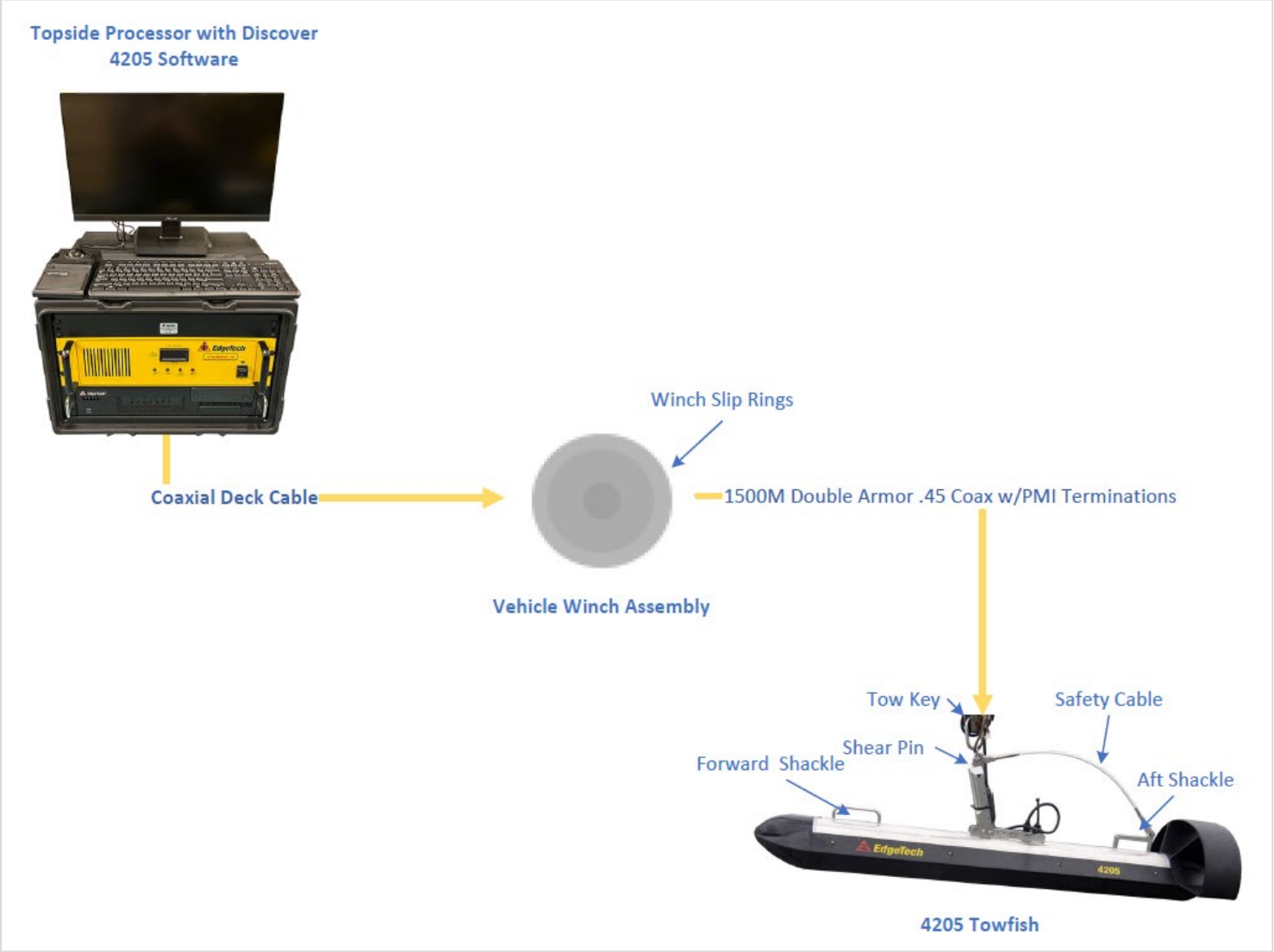

Figure 3-2: Typical 4205 System Diagram using 1500m tow Cable

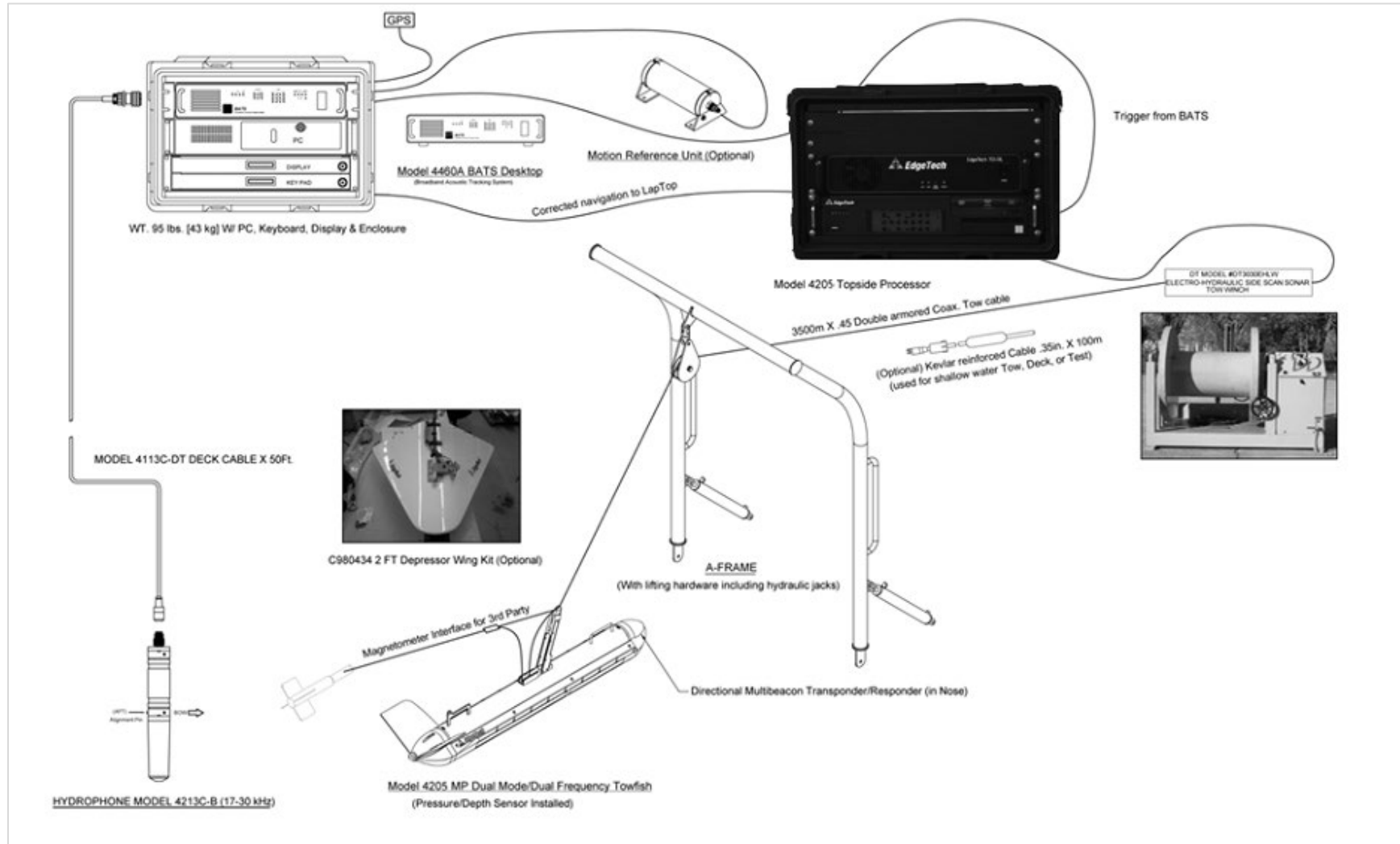

Figure 3-3: 4205 Rack-Mounted System with the Directional Multi-Beacon Transponder/Responder used with the EdgeTech USBL BATS

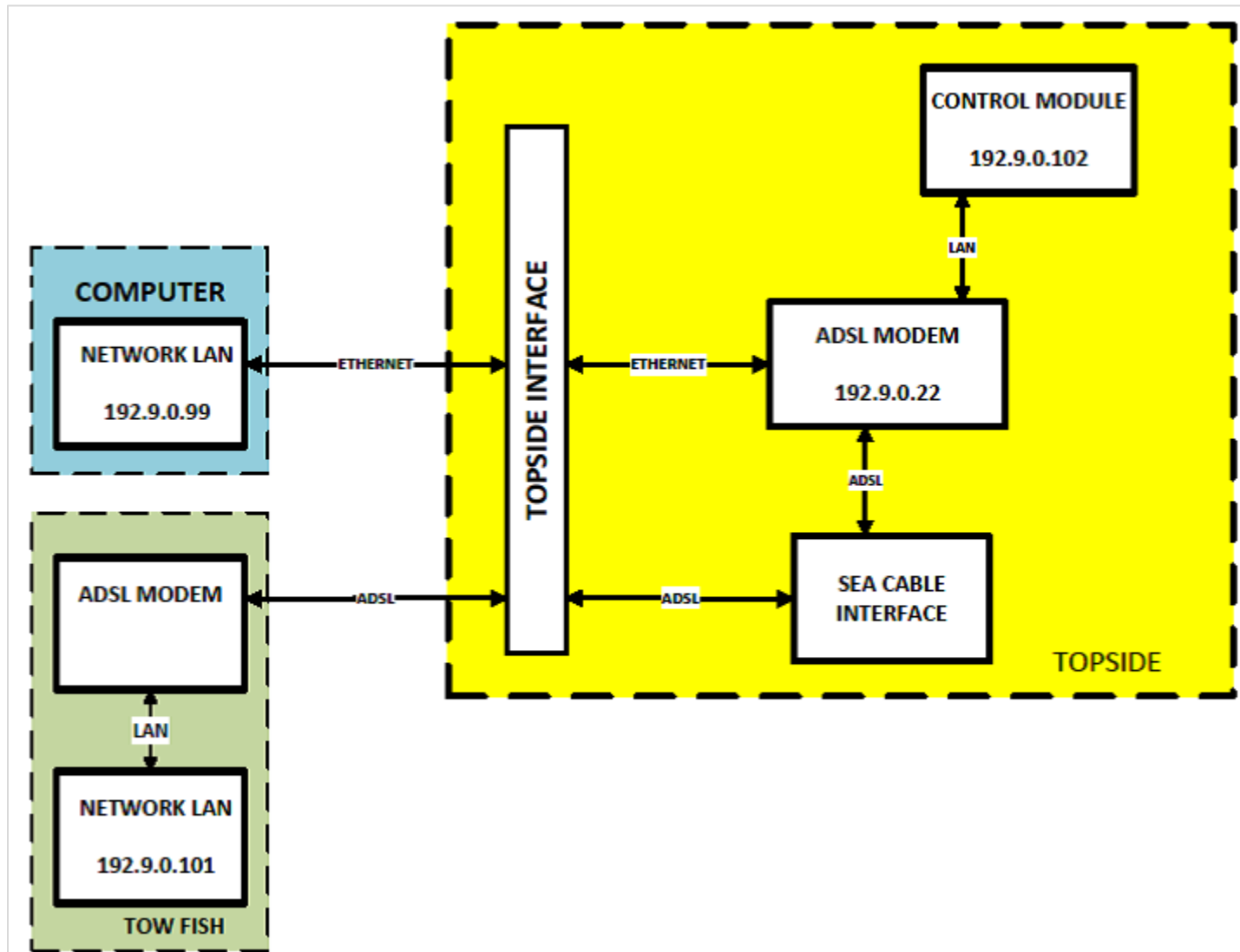

Figure 3-4: Network Interface Diagram

4.0 SYSTEM SETUP

4205 Side Scan Sonar System setup encompasses unpacking, inspecting, connecting, and testing system components.

4.1 Unpacking and Inspection

EdgeTech takes great care in how our products are shipped; however, they could be damaged during shipment. Please inspect the shipping containers for any damage before unpacking the system. Report any damage to the carrier and **CUSTOMER SERVICE**. If the shipping containers appear free of damage, carefully unpack the components and inspect them individually for damage. If any damage is found, report it to the carrier and EdgeTech. Also, check the packing list to verify that all the items on the packing list are included. If any items are missing, immediately contact EdgeTech.

The 4205 Side Scan Sonar System typically includes, at a minimum, the items listed below for each complete sonar system. After unpacking the system components, safely store the shipping containers, including any packing materials, for later use. When transporting or storing the system, pack all items in their original shipping containers and in the same way they were originally shipped. Store the system in a dry environment when not in use.

General system components are:

- 4205 Towfish Assembly (Tri-Frequency or MP/MT configuration)
- Topside Digital Link (Starmux IV or 701-DL)
- Rackmount Computer Configuration with Case (optional)
- AC Power Cord
- Ethernet Patch Cable
- Towfish Accessories Kit

4.2 Power Requirements

The 4205 Topsides and computers require 100–264 VAC, 50/60 Hz, and the systems' voltage sense is auto-switching.

WARNING! Do not connect the tow cable to the topside processor before connecting it to the towfish. Injury or death can occur if the exposed connector on the tow cable is energized. Always connect the tow cable to the towfish first.

4.2.1 Use of an Uninterrupted Power Supply

The AC power source should be continuously free of high amplitude, high-frequency transients, as this type of interference could degrade performance or damage the equipment. An uninterrupted power supply (UPS) with power surge protection is recommended for powering the equipment. However,

whether a UPS is used, do not use the same AC power source used to power electric motors on the survey vessel, such as pumps and winches. Also, do not use switching-type battery chargers or DC-to-AC converters with square wave outputs.

4.2.2 Magnetometer Power

The Starmux IV or 701-DL can power and interface to a 4205 and power a Magnetometer. The difference between the two topsides is their ability to support additional devices (optional) and long cables (up to 6000m in length). Contact **CUSTOMER SERVICE** to discuss specific applications/options and cabling requirements.

4.2.3 Change to a Non-US Power Plug

An AC power cord is provided for connecting the deck unit to a standard U.S. 3-pronged outlet. For non-U.S. power outlets, users can modify this cord by cutting off the 3-pronged plug and attaching the appropriate plug.

AC POWER CORD WIRE COLOR	FUNCTION
Black	AC line
White	AC neutral
Green	Earth ground

Table 4-1: AC Power Wiring Wire Colors for Conversion

4.3 Navigation Interface

Navigation devices are installed by physically connecting the device to the topside computer's serial port. If it is an EdgeTech computer, serial port COM1 has been configured to accept this connection. If this is not an EdgeTech-configured computer, the port can be configured in Discover by going to the Top Menu, selecting Configuration, and then Serial Ports (**FIGURE 4-1**) from the dropdown menu. You then enable the port, specify the port on the computer and the baud rate. The GPS device's manufacturer will provide the baud rate in their user's manual to match. Refer to the **DISCOVER 4205 SOFTWARE MANUAL** for more configuration details.

The 4205 Side Scan Sonar System accepts all standard National Marine Electronics Association (NMEA) 0183 message sentence formats from a connected global positioning system (GPS) or integrated navigation system.

The screenshot shows the 'Configure Serial Ports' window with the following settings:

- Enable Primary Navigation Input:** Checked. Port: COM1, Baud Rate: 9600. Description: Used for NMEA input of GPS and Navigation.
- Enable Cable Counter Input:** Port: OFF, Baud Rate: 9600. Description: Select Port to monitor Cable Counter.
- Enable Secondary Navigation Input:** Unchecked. Port: OFF, Baud Rate: 9600. Description: Used for other NMEA data input.
- Enable KP Input:** Port: OFF, Baud Rate: 9600. Description: Select port for KP input.

Figure 4-1: Discover Serial Port Configuration

4.4 Topside Processor Placement

The topside should be located in a dry, sheltered area protected from weather and water spray. The unit requires an environment where the temperature is consistently between 0°C and 45°C (32°F and 113°F). Furthermore, avoid areas of direct sunlight, especially in tropical environments, as heat buildup could damage the equipment, and glare could hinder the user's ability to see LCDs, digital displays, and status indicator lights. The processor's location should allow users to communicate directly with the deck crew that is handling the vehicle. Secure the topside processor in place, using tie-downs near the required AC power source if necessary. Also, ensure ample room behind the rack for connecting the cables. Support the components inside the rack using appropriate mounting brackets and secure the front panels using standard panel mounting hardware.

WARNING! Never operate or open the unit where it can become wet from sea spray or precipitation. Injury or death from electric shock can occur, as well as damage to the equipment.

4.5 TCP/IP Address Settings

The 4205 Side Scan Sonar System includes many Ethernet devices connected to a common local area network (LAN). Each device has a factory-set TCP/IP address, which does not require changing under normal circumstances. Should any of these devices be replaced or upgraded later, the TCP/IP addresses may need reconfiguring.

A data connection between the computer and Starmux or 701-DL digital link is configured by setting the computer's network interface card IPv4 address. If you are connecting a computer not preconfigured by EdgeTech, you must manually set the IPv4 address of your computer to *192.9.0.nnn*, where *nnn* is any integer from 1 to 100, with the exception of the reserved IP numbers listed in [TABLE 4-1](#). The only other field in the Windows Manual IP settings to be populated is the Subnet Mask, which should be set to *255.255.255.0*. You do not need to populate the Default Gateway. The *Obtain DNS Server Address Automatically* radio button is automatically selected by Windows, so the Preferred DNS Server and Alternative DNS Server fields do not need to be populated.

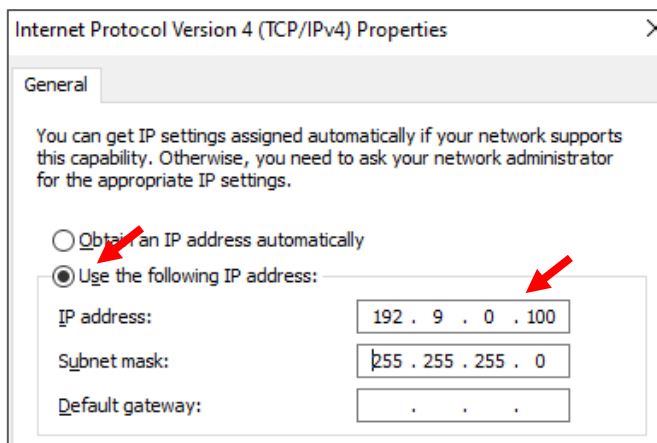

Figure 4-2: Windows Manual IP Properties Window

SYSTEM	COMPONENT	RESERVED IP
Starmux IV	Topside Modem	192.9.0.22
701-DL	Topside Netburner	192.9.0.102
701-DL	Topside Modem	192.9.0.22
4205 + 701-DL	Preconfigured Topside CPU Wired LAN	192.9.0.99
4205 + Starmux IV	Topside Modem	192.9.0.22 (Starmux IV)
4205 + Starmux IV	Towfish Modem	192.9.0.33 (No Access)
4205 + Starmux IV	Preconfigured Topside CPU Wired LAN	192.9.0.99
4205 + Starmux IV	Preconfigured Topside CPU Wireless	192.9.0.100
4205 + Starmux IV	Towfish CPU	192.9.0.101
4205 + Starmux IV	Not Recommended	192.9.0.104-192.9.0.225

Table 4-2: EdgeTech Default Reserved IP Numbers By System and Component

4.6 Connecting the System Components

The 4205 standard system component configuration is as follows. The 4205 Towfish is physically connected to a Starmux or 701-DL digital link using a Kevlar or armored tow cable. The digital link is physically connected to a Discover-enabled computer utilizing Ethernet Ports on each via a CAT-5 Ethernet patch cable. Navigation systems, displays, mouse, and keyboard are typically connected to the computer using serial, video, and USB cables and connections. An external trigger is connected to the digital link's rear panel. Towfish wings, magnetometers, and other custom options are physically attached to the towfish. The sections below provide detailed instructions for connection each component.

WARNING! Do not connect the tow cable to the topside processor before connecting it to the towfish. Injury or death can occur if the exposed connector on the tow cable is energized. Always connect the tow cable to the towfish first.

4.6.1 Connect and Attach the Tow Cable to the Towfish

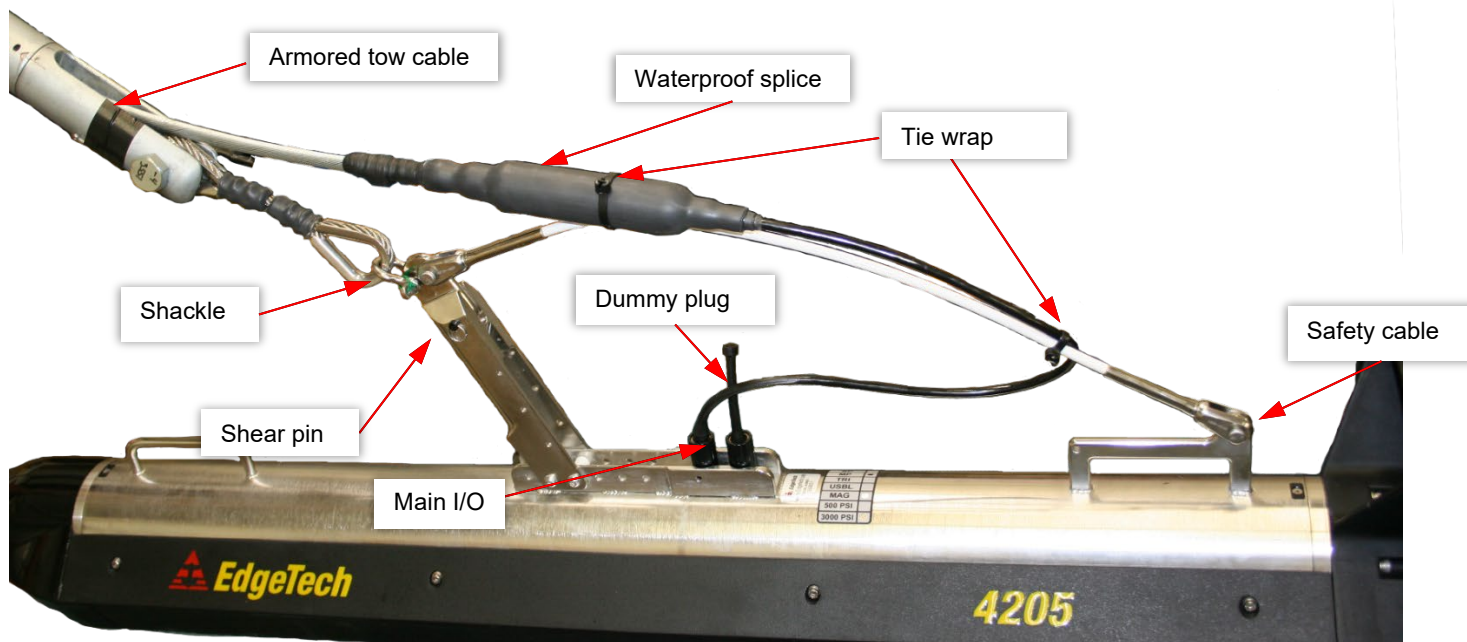

Figure 4-3: 4205 Towfish with Armored Tow Cable

1. Verify that the tow cable is not connected to the topside processor.
 2. Attach the tail cone to the towfish and secure it with the four hex socket bolts provided.
 3. Verify that the tow cable connector on the towfish and the input mating connector on the tow cable are free of corrosion or dirt. If it is dirty, clean it with an alcohol wipe.
 4. Apply a thin film of silicone grease to the pins of the tow cable connector on the towfish.
 5. Mate the connectors by pressing them firmly together. Do not wiggle the connectors.
 6. Secure the connector locking sleeve.
 7. Attach the loop of the safety grip to the shackle on the towing arm and secure the shackle bolt with seizing wire or a tie wrap.
 8. For an **Armored** tow cable, attach the waterproof splice to the side of the tow arm with a zip tie. Attach the coupling cable thimble to the tow arm key shackle and the other end of the coupling cable to the PMI grip. Secure the PMI grip with seizing wire or zip ties and a cotter pin.
- For **Kevlar** tow cables, insert the tow cable splice into the recess in the tow arm and secure the splice with two tie wraps. Holes in the towing arm are provided for this purpose.
9. Verify that the dummy plug is installed on the option connector if not used.

4.6.2 Installing a Depressor Wing and Connecting the Tow Cable

Please see [MANUAL ADDENDUM \(PN# 0021771\) DEPRESSOR WING](#) for wing installation and cable connection instructions. Once completed, continue to the [CONNECTING TO THE TOPSIDE](#) section of this manual.

4.6.3 Connecting to the Topside

The subsections below describe how to connect the towfish to the topside by configuration. Please skip ahead to the appropriate subsection, depending on your configuration.

4.6.3.1 Connecting to the Starmux IV DL

Refer to the [STARMUX IV MANUAL \(PN# 0023786\)](#) for the location of the connectors while performing the steps below:

1. Verify that the Starmux IV DL is not connected to AC power.
2. Verify that the tow cable is properly connected and attached to the towfish, and then connect the tow cable to the Sea Cable Connector on the rear panel of the Starmux IV.
3. Connect the Ethernet patch cable to the DATA Ethernet Connector of the Starmux IV Digital Link and the computer's ethernet connector. If it is an EdgeTech 2U, connect to the right-side Ethernet Connector. Any Category 5 Ethernet patch cable (max length = 100ft) can be used.
4. Set the IP address of your computer to 192.9.0.nnn, where nnn is any integer from 1 to 100. The factory default is an IP address of 192.9.0.101 and a port setting of 1700. Do not use 192.9.0.22, 192.9.0.225, and 192.9.0.102, as they are reserved. See the [TCP/IP ADDRESS SETTINGS SECTION](#) of this manual for further instructions and details.
5. If a navigation system is used, connect the navigation system output to an available serial communications port on the computer.
6. If an external source triggers the Starmux IV Digital Link, connect this source's trigger output to the rear panel FSK connector.
 - The Starmux IV comes standard with a FSK (Frequency Shift Keyed) Trigger BNC Connector on the rear panel, which connects with a USBL (Ultra-Short Baseline Beacon) navigation and positioning system. A positioning system provides a precise position of the towfish, which can help make better towfish and sonar deployment/configuration decisions. This trigger does not directly control the sonar subsystems in any way but is used to trigger a positioning beacon. The triggering pulse must have a width of 10ms pulse rate or greater, or the triggering pulse will not be recognized.
7. Connect the AC power cord to the Line VAC connector and the AC power source.

4.6.3.2 Connecting to the 4205 Rack Mount with Starmux IV DL

Refer to [STARMUX IV MANUAL \(PN# 0023786\)](#) for the location of the connectors while performing the steps below:

1. Verify that the Starmux IV DL is not connected to AC power.
2. Follow interface instructions for the Starmux IV under [SECTION 4.6.3.1](#).
3. Connect the LCD monitor cable connector to the computer's video card connector.
4. Connect the trackball to the computer's back panel USB connector.
5. Connect the keyboard to the computer's back-panel USB connector.
6. If a navigation system is used, connect the output to the computer's back panel COM 1 Serial Port.
7. Connect the 2U Computer and Starmux IV AC power cords to their VAC connectors and AC power source.

4.6.3.3 Connecting to the 701-DL

Refer to the [701-DL HARDWARE MANUAL \(PN# 0004809\)](#) for the location of the connectors while performing the steps below:

1. Verify that the 701-DL is not connected to AC power.
2. Verify that the tow cable is properly connected and attached to the towfish, and then connect the tow cable to the Sea Cable Connector.
3. Connect the Ethernet patch cable to the Data Connector of the 701-DL Digital Link and the computer's Ethernet connector. This cable may be extended up to 100 feet using a Category 5 Ethernet crossover or straight patch cable.
4. Set the IP address of your computer to 192.9.0.nnn, where nnn is any integer from 1 to 100. The factory default is an IP address of 192.9.0.101 and a port setting of 1700. Do not use 192.9.0.22, 192.9.0.225, 192.9.0.101, and 192.9.0.102, as they are reserved. See the [TCP/IP ADDRESS SETTINGS SECTION](#) of this manual for further instructions and details.
5. If a navigation system is used, connect the navigation system output to an available serial communications port on the computer.
6. If an external source will be used to trigger the 701-DL Digital Link, connect the trigger output of this source to the Sync Connector.
7. Connect the AC power cord to the Line VAC Connector and the AC power source.

4.6.3.4 Connecting to the 4205 Rack Mount with 701-DL

Refer to the [701-DL HARDWARE MANUAL \(PN# 0004809\)](#) for the location of the connectors while performing the steps below:

1. Verify that the 701-DL Rack Mount is not connected to AC power.
2. Follow connection instructions for the 701-DL under [SECTION 4.6.3.3](#).
3. Connect the LCD monitor to the Monitor connector.
4. Connect the trackball to a back-panel USB connector.
5. Connect the keyboard to a back-panel USB connector.
6. Connect the 2U Computer and 701DL AC power cords to their VAC Input Connectors and AC power source.
7. Connect an AC power cord to the LCD monitor and the AC power source.

5.0 SYSTEM ACTIVATION, TEST, AND DEPLOYMENT

The 4205 can be activated after the connections to the topside processor have been completed. However, a few pre-deployment checks are required before the deployment of the towfish to verify that the system is operating properly.

When performing the system activation and test, refer to the **TOPSIDE TECHNICAL DESCRIPTIONS** subsection for the location and description of the Topside processor's controls and indicators. Also, should the system not activate properly or the pre-deployment checks fail, refer to section **7.0: TROUBLESHOOTING** for assistance in isolating and correcting common problems.

5.1 Activating the Topside

The subsections below describe how to activate each of the three Topsides. Please follow the instructions pertinent to your system's configuration.

5.1.1 Activating a Starmux IV System

To activate the Starmux IV Digital Link System:

1. Turn on the computer and launch the EdgeTech Discover application.
2. Turn on the line power switch on the back panel of the Starmux IV Digital Link. This switch can always be left in the ON position if desired.
3. Turn the front panel's power switch to **ON**.
4. The PWR light should illuminate after several seconds, as the link is established, the Fish PWR indicator light should illuminate; the LAN indicator light should flash continuously, and the LINK indicator light should flash while a reliable communications link with the Towfish is being established and then illuminate continuously when the link is completed. Also, the **NET** Radio Indicator Tab in the lower control panel of the Discover application UI should display:

NET: ON

5.1.2 Activating a 701-DL System

To activate the 701-DL Digital Link System:

1. Turn on the computer and launch the Discover application.
2. Turn on the line power switch on the back panel of the 701-DL Digital Link. This switch can always be left in the ON position if desired.
3. Turn the front panel's power switch to **ON**.

4. The fish power indicator should illuminate, the LAN indicator should flash continuously, and the LINK indicator should flash while a reliable communications link with the towfish is being established. Then, the indicator should illuminate continuously when the link is completed. The NET radio Indicator Tab in the lower control panel of the Discover application UI should display:

NET: ON

5.2 SBG AHRS Usage

Historical EdgeTech towfish compasses have been pure magnetic field measuring devices that provide a heading relative to magnetic North, which is then adjusted by manually setting a regional declination value. The intent was to provide the operator with towfish heading, pitch, and roll data to know how the towfish's motion impacted data collection quality. This information was suitable for this limited intent but not ideal for processing raw data because of the inaccuracies caused by variable magnetic influences of materials in the towfish, tow vessel hull construction, the environment, and targets themselves. Our suggestion to overcome these issues is to use *course-made-good* heading information to process side scan data and accurately position targets.

The introduction of the 4205 has allowed us to improve the heading sensor's performance by fitting a MEMS-based inertial motion sensor unit that combines data from a built-in gyroscope, accelerometer, and magnetic field sensors using a Kalman filter algorithm. The incorporation of rate-gyro data means that the relative heading is much more stable. Overall, the sensor provides a more reliable output that is less susceptible to short-term magnetic field variations. The absolute heading still relies on magnetic field measurement and is subject to some of the limitations outlined above.

Care still needs to be taken when using the AHRS data for target positioning. External magnetic fields may not be adequately allowed for when the factory calibration is performed. The local magnetic declination correction should be applied before beginning any survey.

EdgeTech AHRS Verification Procedures

The factory acceptance and verification tests for this sensor are run at a magnetically quiet site. They include running hard iron and soft iron compensations once the sensor is installed in the towfish, followed by GPS-based verification of true north accuracy. To accommodate these tests, a rigid fixture supports the towfish and allows any misalignments between the mounted sensor and the towfish's longitudinal axis to be measured. The resultant offset is applied as a correction in the sensor software as part of the AHRS verification procedure. Each towfish is accompanied by an AHRS verification certificate confirming that the towfish's AHRS meets specifications.

Customer Options for Applying Magnetic Declination

The Heading sensor has the ability to take a local latitude and longitude and apply a local magnetic declination adjustment to the heading measurements, thus providing true north measurements as

outputs. EdgeTech offers two options to configure this, with the first being preferred as there are fewer potential points of error.

1. The latitude and longitude that lie on one of the agonic lines (zero magnetic declination) will be entered before shipping the system. This means that, effectively, no magnetic declination will be applied to the raw heading data, such that any magnetic declination corrections can be applied in post-processing.
2. Alternatively, the user can enter local latitude, longitude, and date for the area in which they are operating and apply magnetic declination before outputting heading data from the sensor. This method requires that the user run the Ellipse Calibration Application on the towfish to enter and save each new site's settings. If the user incorrectly applies the settings or simply forgets to do this and leaves the settings from a previous site, the heading measurements will be incorrect. If this option is chosen, please contact [EDGE TECH CUSTOMER SERVICE](#) for support and instructions.

5.3 Performing Pre-deployment Checks

Pre-deployment checks should be performed after the system is activated and before the towfish is deployed. These checks involve verifying that data can be recorded and played back in Discover, rubbing one's hand on the transducer arrays while observing the Sonar display in the Discover Main window, verifying correct heading, pitch, and roll outputs, and zeroing the pressure sensor.

1. Activate your system using the specific instructions detailed above.

CAUTION! Do not allow the towfish's transducer arrays to continuously transmit in the air for an extended period (> 5 minutes), as damage to the transducer arrays could occur.

2. In Discover, click the Towfish Control (4205 MPMT) or Sidescan Control (4205 Tri-Frequency) tab in the Lower Control panel, shown in [FIGURE 5-1](#) and [FIGURE 5-2](#).

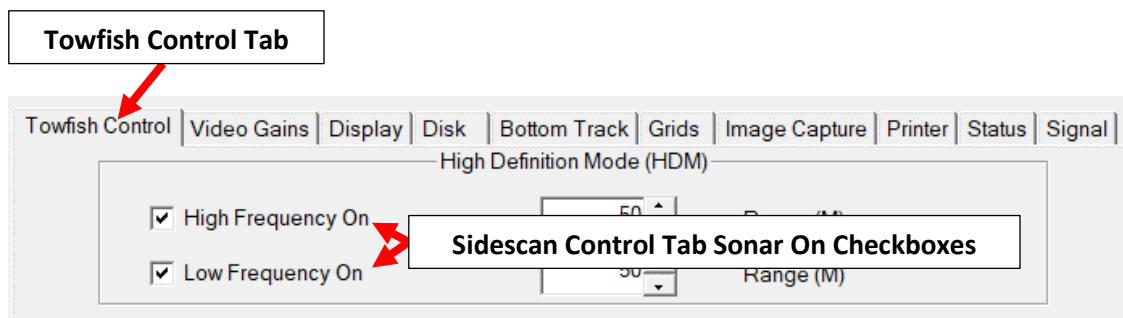

Figure 5-1: Discover 4205 MPMT Sonar Activation

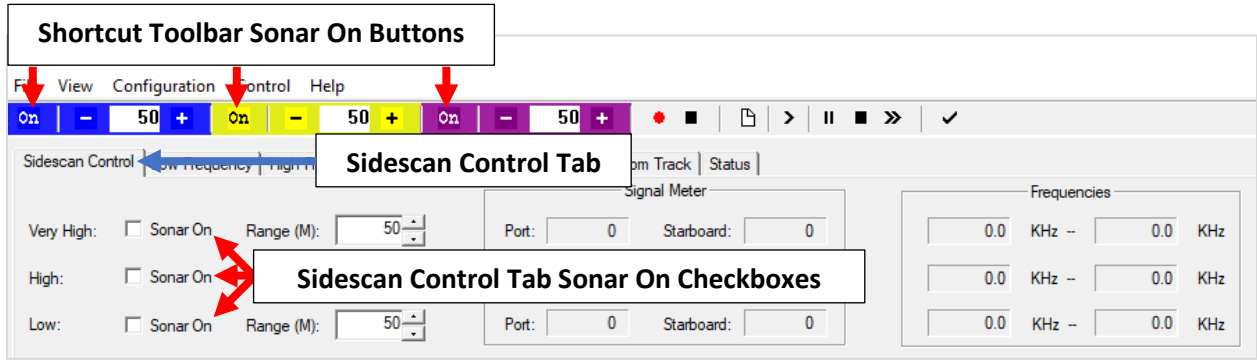

Figure 5-2: Discover 4205 Tri-Frequency Sonar Activation

3. Turn the sonar systems on to ensure they work properly. To do so, select the **High Sonar On** and **Low Sonar On** checkboxes for Discover 4205 MPMT or any two of the **Very High Sonar On**, **High Sonar On**, and **Low SONAR On** checkboxes for Discover Tri-Frequency software. Alternatively, the Tri-Frequency Shortcut Toolbar’s blue (low frequency), yellow (high frequency), and purple (very high frequency) buttons can be used as well. The transducer arrays on the towfish should begin transmitting, and data should start scrolling on the Sonar display in the Discover Main window. For a Tri-Frequency system, the testing should be repeated for all three sonar frequencies. Two can be selected at a time.
4. Set the ranges for very high (tri-frequency), high, and low frequencies to at least 100 meters by entering the value in the Sidescan Control Tab or Shortcut Toolbar Range fields. Click the **N** and **T** buttons on the Discover Shortcut Toolbar to normalize Gain and Time Variable Gain (TVG), which corrects for losses due to range.

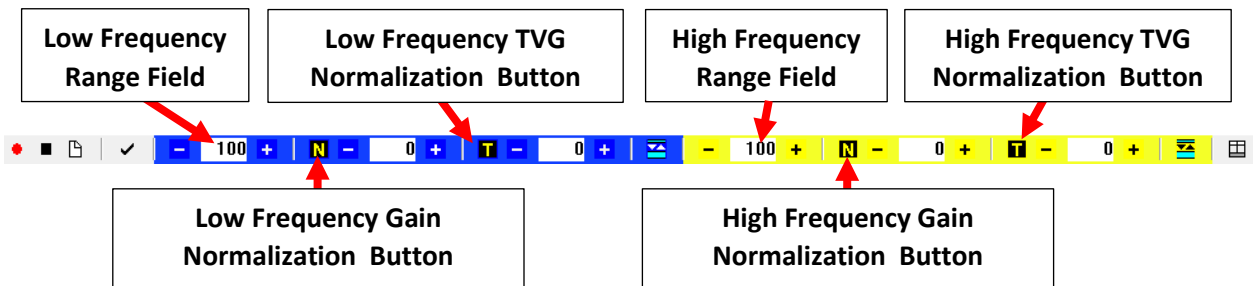

Figure 5-3: 4205 MPMT Shortcut High and Low-Frequency Range Fields and N (Gain) and T (TVG) Buttons

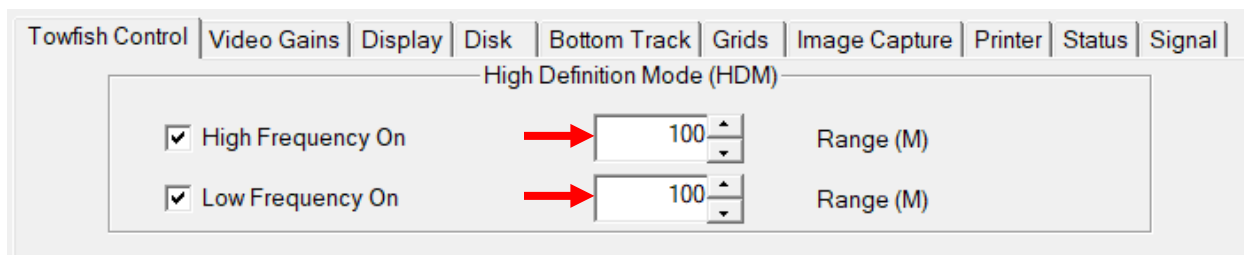

Figure 5-4: 4205 MPMT Towfish Control Range Fields

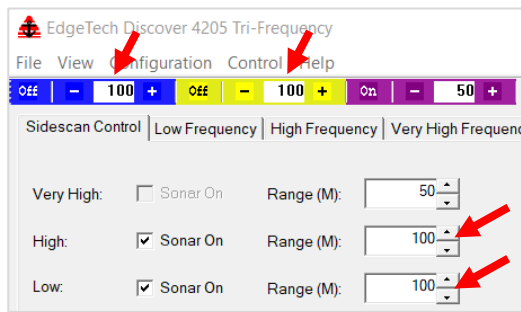

Figure 5-5: Tri Frequency Range Entry Fields

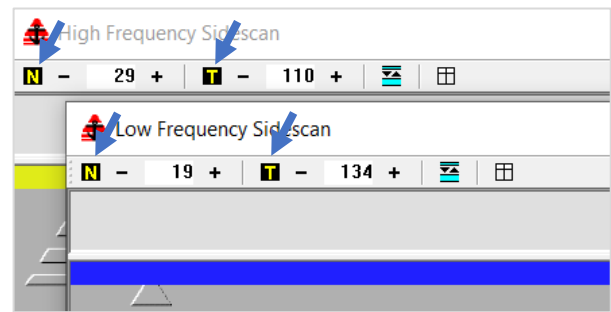

Figure 5-6: Tri-Frequency Gain and TVG Buttons

5. Start recording data by pressing the red record button on the **Discover Toolbar** or **Disk Tab**.



Figure 5-7: 4205 MPMT Shortcut Toolbar Record Button Location

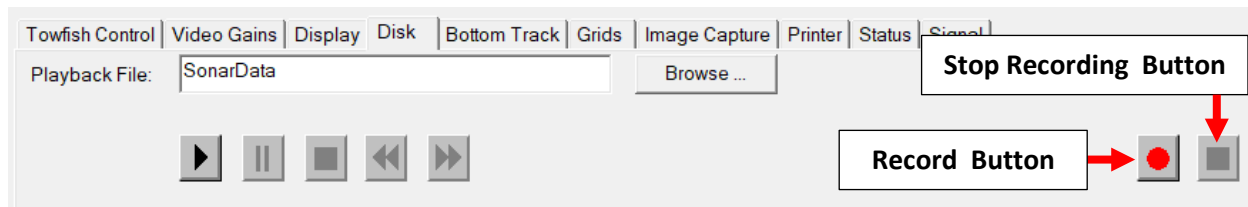

Figure 5-8: 4205 MPMT Recorder Play and Stop Buttons

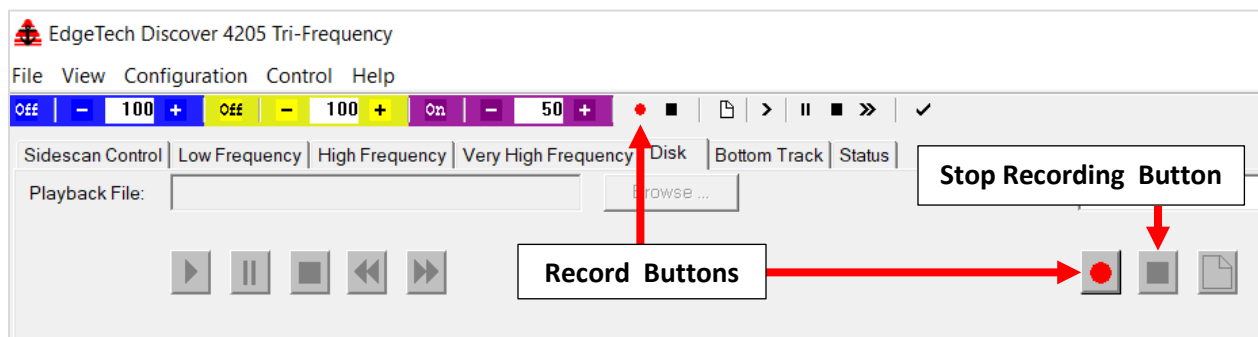

Figure 5-9: 4205 Tri-Frequency Record and Stop Buttons

6. Rub the port and starboard transducer arrays from port to starboard and back to port while observing the Discover main window's sonar display. Streaks or noise spikes should be observed in the waterfall display in the same order as the transducers were rubbed (port-starboard-port) if they are working correctly.

- Stop the recording (see [FIGURE 5-8](#) or [FIGURE 5-9](#)) and playback the file by pressing the play button in the playback controls or shortcut toolbar ([FIGURE 5-10](#), [FIGURE 5-11](#), or [FIGURE 5-12](#)) to ensure that data is recorded correctly.

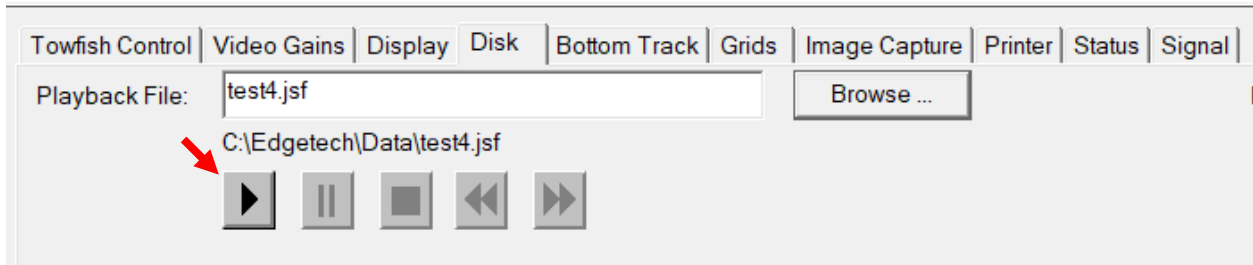

Figure 5-10: 4205 MPMT Disk Tab Playback Controls Play Button

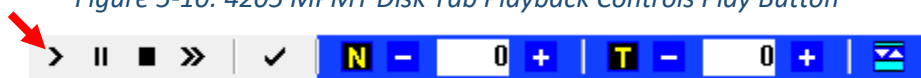

Figure 5-11: 4205 MPMT Shortcut Toolbar Play Button

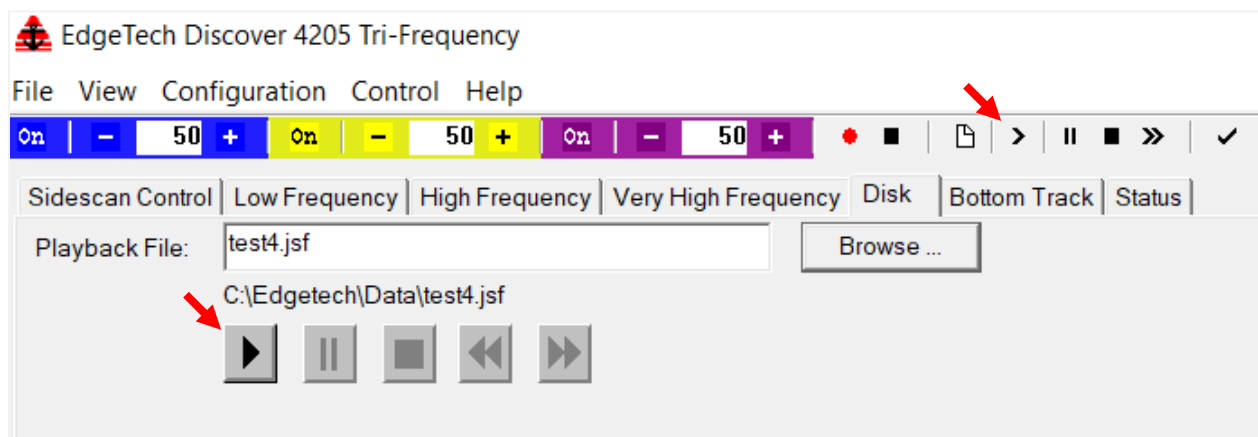

Figure 5-12: 4205 Tri-Frequency Shortcut Toolbar and Disk Tab Playback Controls Play Button

- Test that the vehicle's compass or AHRS works properly by moving the towfish and checking that the heading, pitch, and roll are reported correctly in Discover's Main Status Line Display.

Heading: NA Pitch: 0.0 Roll: 0.0 Altitude: NA Depth: NA SV: 1500

Figure 5-13: Heading, Pitch, and Roll Datablock Locations on Top Line of Main Status Line Display

- Verify that the starboard roll is correct by rotating the tow arm of the fish towards its starboard direction around 20 degrees. The Roll value should be positive in this direction. (max is +180 degrees).
- Verify that the port roll is correct by rotating the tow arm of the fish towards its port direction around 20 degrees. The Roll value should be negative in this direction. (max is -180 degrees).

- Verify that the pitch is working properly by lifting the nose of the fish. The pitch value should read positive and reach a max of +90 degrees.
 - Verify that the pitch is working properly by lifting the tail of the fish. The pitch value should read negative and reach a max of -90 degrees.
 - Verify that the heading works properly by rotating the fish clockwise along the horizontal plane. The heading should increase in value and reach a max of +359.9 degrees. Rotating the fish counterclockwise should decrease the heading value.
9. If a pressure sensor is installed, verify that the pressure display indication is at or nearly zero. The Pressure sensor can be zeroed on deck in Discover, under **External Device Controls**.

5.4 Towfish Deployment

The 4205 Tri-Frequency or a MP/MT Towfish used in SP mode can be towed at speeds of up to 4.8 knots while still meeting NOAA and IHO-44S specifications of 3 pings on a 1-meter cubed target at 100 meters range. The 4205-MP/MT Towfish can be towed at speeds of up to 9.6 knots with the same results when operating in High-Speed Mode (HSM). **FIGURE 5-14** depicts the 4205 as it is hung from a vessel's winch. Note the slight upward tilt of the unit while in the air.



Figure 5-14: 4205 Towfish Deployment

NOTE: The deployment instructions below are only meant as a general guide. Due to varying conditions, exact deployment methods will change, and it is up to the end-user to modify their deployment procedure to match the conditions they are working under.

CAUTION! When lowering the towfish in an area where the bottom topography is unknown, take care not to strike the bottom or a submerged object. Otherwise, damage to the towfish may occur. Always monitor towfish altitude during the survey. Failure to do so may result in the towfish hitting bottom or becoming snagged.

CAUTION! Do not tow the towfish too close to the survey vessel. Towing in this manner can cause the Towfish to be pulled in against the ship's hull due to the low pressure of the propeller wash and the effect of the water flowing by the hull. Also, sonar reflections from the hull may be evident in the records.

CAUTION! Do not tow the towfish with the nose angled up or down. Doing so can degrade the sonar imagery. Verify that the towfish is as level as possible when towing it.

NOTE: For detailed information about the Discover software, including recording data, refer to the [DISCOVER 4205 SOFTWARE MANUALS](#).

To Deploy the Towfish:

1. With the survey vessel underway at up to two knots, slowly and carefully lower the towfish into the water, well away from the propeller. However, if practical, the survey vessel should be put in neutral. Do not let the towfish strike the survey vessel hull.
2. Lower the towfish to a depth of about three meters or just below the propeller wash.
 - a. Click the Towfish Control tab and set a range for each frequency. Refer to [FIGURE 5-4](#) and [FIGURE 5-5](#) for range field locations.
 - b. Click the N and T buttons on the Shortcut Toolbar in Discover to normalize gain and TVG (See [FIGURE 5-3](#) for MPMT and [FIGURE 5-6](#) For Tri-Frequency button locations).
3. Click the Bottom Track Tab in the Lower Control panel.

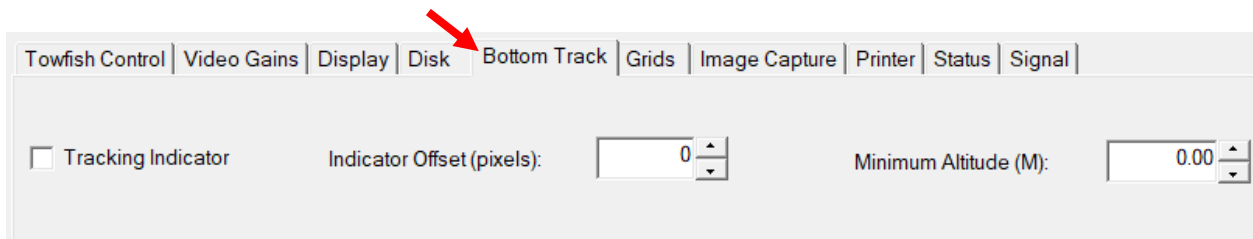

Figure 5-15: 4205 MPMT Bottom Track Tab

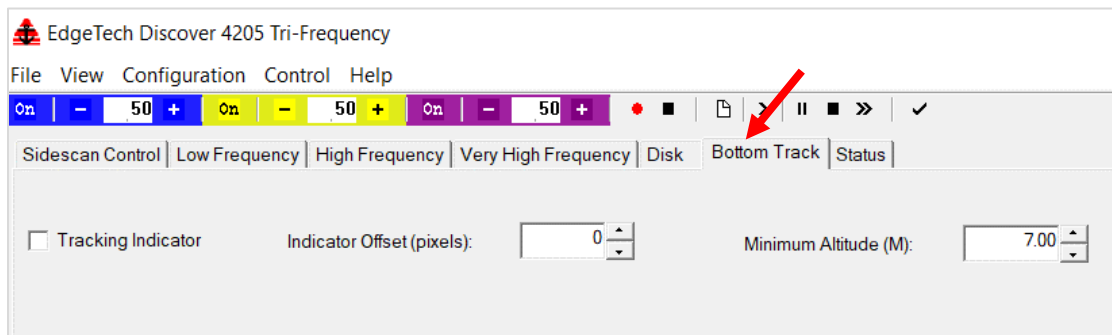

Figure 5-16: 4205 Tri-Frequency Bottom Track Tab

NOTE: The Bottom Tracker is best used with updated nautical charts and an operator with survey area and deployment expertise.

4. Make the required settings to track the bottom and note the Towfish altitude in the Altitude display. Lower the towfish so its altitude is 10–15% of the range selection. Refer to the Discover Software Manual for details on bottom tracking setup.
5. Increase the survey vessel speed to the desired survey speed and adjust the amount of cable out such that the altitude of the towfish remains at 10–15% of the range selection.
6. If a pressure sensor is installed, verify that the pressure display indication is correct.
7. Secure the tow cable to the survey vessel.
8. Begin recording data.

5.5 Towfish Recovery

CAUTION! The following procedure is only meant as a general guide. Due to varying conditions, exact recovery methods will change, and you must modify your procedure to match your working conditions.

To recover the Towfish:

1. Slowly retrieve the tow cable until the towfish is just below the surface.
2. Using Discover, turn the sonar off by deselecting all Sonar ON checkboxes in the Towfish Control Tab (4205 MPMT) or Sidescan Control Tab (4205 Tri-Frequency) (FIGURE 5-1 and FIGURE 5-2). Alternatively, pressing The OFF buttons in the Shortcut Toolbar will also deactivate the sonar.

3. Slow the survey vessel speed to under two knots.

NOTE: If practical, put the survey vessel in neutral while the towfish is pulled onboard.

4. Recover the towfish from the water and carefully lower it onto the deck.
5. Turn off the topside processor.
6. Disconnect the tow cable from the 6-pin male tow cable connector on the towfish. Inspect the connector; clean and lubricate as necessary.

WARNING! Do not disconnect the tow cable before turning the power off. Injury or death can occur if the exposed connector on the tow cable is energized.

7. Install the 6-pin female dummy plug on the 6-pin male bulkhead connector on the towfish.
8. Refer to the **MAINTENANCE** section of this manual for instructions on cleaning and inspecting the towfish, the tow cable, and the underwater connectors after use.

6.0 MAINTENANCE

The 4205 Side Scan Sonar System is ruggedly designed and built, requiring little maintenance. However, some periodic maintenance is recommended to ensure long-lasting and reliable service. Inspection of the 4205 should be performed regularly but always before a deployment. Maintenance should be performed as necessary.

6.1 Inspect and Clean the Towfish and Cable after Use

Wash down the towfish and tow cable with freshwater after use. Thoroughly spray the transducer arrays and remove any buildup of debris. Inspect the cables and connectors for any damage and check for loose connections. Also, inspect the tow cable and the connectors on each end and install the dummy plug.

The transducer arrays can be cleaned using a mild, non-abrasive detergent and freshwater. Do not use any abrasive detergents or ammonia-based cleaners. After cleaning, thoroughly spray the transducer arrays again with fresh water.

6.2 Inspect and Clean the Underwater Connectors

Regularly inspect each underwater connector in the towfish and the tow cable for corrosion or oxidation. To remove any oxidation, rub the contacts lightly with an 800-grit emery cloth cut into strips equal to or less than the width of a contact. A pencil eraser can also be used for this purpose. The input sockets can be cleaned using a cotton swab and rubbing alcohol. A .22 caliber bore brush with only nylon bristles can remove light oxidation.

To extend the connectors' life and increase their reliability, apply a thin film of silicone dielectric grease, such as Novagard G624 general-purpose silicone grease or an equivalent, to the entire surface of each male pin. A small amount of grease should also be applied to the opening of each female socket.

NOTE: Remember to protect connectors with dummy connectors and caps.

6.3 Storage

When not in use, all the components of the 4205 System should be packed in their original shipping containers the same way they were originally shipped. Store equipment in a dry area when not in use.

6.4 Recommended Spares

EdgeTech recommends purchasing spare parts simultaneously with purchasing the original equipment. Doing so ensures all spares are of the same make and model as the equipment's originals. See [SPARE KITS](#) and contact [CUSTOMER SERVICE](#) for a list of recommended items.

7.0 TROUBLESHOOTING

Following the instructions in the previous sections and performing regular maintenance, the user should seldom encounter bugs with the 4205 System. However, If problems occur, this section will help users diagnose and fix simple bugs. It includes basic troubleshooting techniques, connector pin-outs, and wiring information to identify and correct possible setup or operational problems.

If you encounter more serious bugs or if the techniques below fail to address the problem, please contact **CUSTOMER SERVICE**.

7.1 Disassembling and Reassembling the Towfish

The procedures below describe how to disassemble and reassemble a Towfish to access and remove the electronics chassis. The tools required are a 5mm Allen wrench [PN# 0020968], a Phillips 01 screwdriver [PN# 0006970], and pliers [PN# 0006968].

WARNING! High Voltages that can cause injury or death are present in the towfish. Turn off the topside processor and disconnect the tow cable before disassembling the towfish.

CAUTION! Opening the electronics chassis may void the user's warranty unless preapproved by EdgeTech. Contact EdgeTech Customer Service before opening the chassis.

7.1.1 Disassembling the 4205 Towfish:

1. Place the towfish on a clean, dry, flat surface.
2. Unscrew and remove the [4] mounting screws that secure the tail to the back of the tow vehicle using an Allen wrench.
3. Pull the tail from the vehicle carefully.

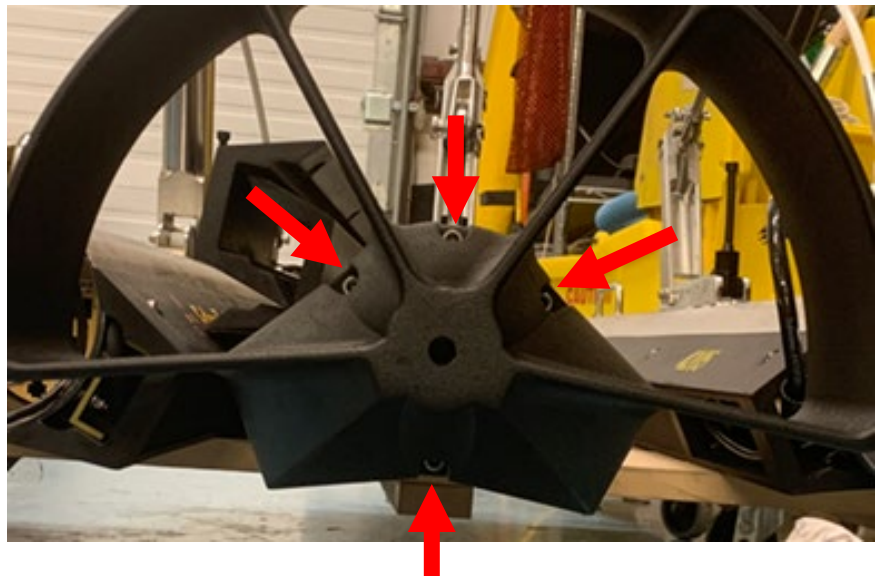

Figure 7-1: Tailfin Removal

4. The aft endcap should now be exposed. Carefully disconnect all of the transducer cables from their connectors.



Figure 7-2: Aft Endcap Cable Disconnection

5. Remove [2] screws and [2] finishing washers from both the forward and aft sides of the housing using a Phillips screwdriver.



Figure 7-3: Side Seal Screw and Washer

6. Remove the nylon retaining lines from both the forward and aft side of the housing where the finishing screws and washers were removed. To remove, grip the nylon retaining line with needle nose pliers and pull it completely out of the housing. It may be necessary to push on the endcap for leverage to remove the line. Installing the supplied grip can facilitate this (see [STEP 9](#)).

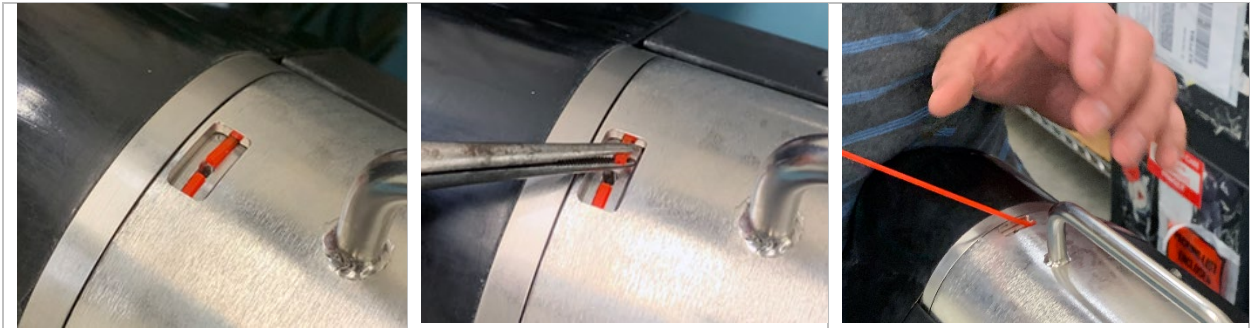

Figure 7-4: Nylon Retaining Line Removal

7. Carefully remove the nose cone by pulling it from the vehicle.



Figure 7-5: Nose Cone Removal

- The forward endcap is now exposed. Carefully disconnect all cables from their connectors.

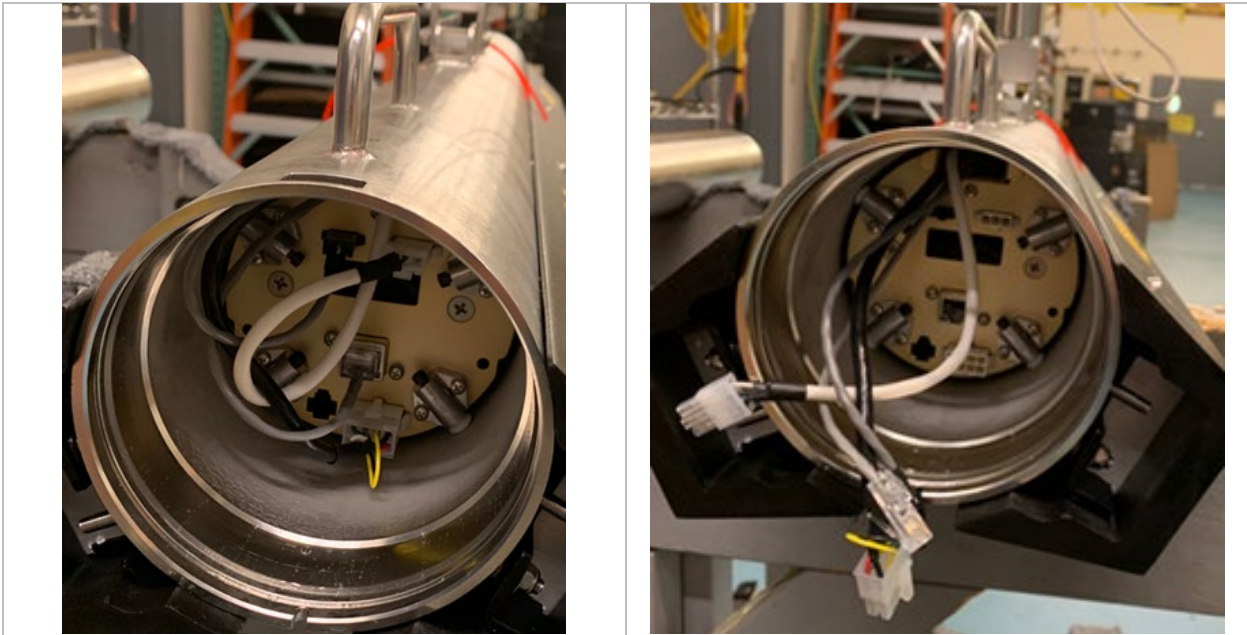

Figure 7-6: Forward Endcap Cable Disconnections

- Attach the EdgeTech-supplied grip handle to the aft endcap by threading in the bolts.

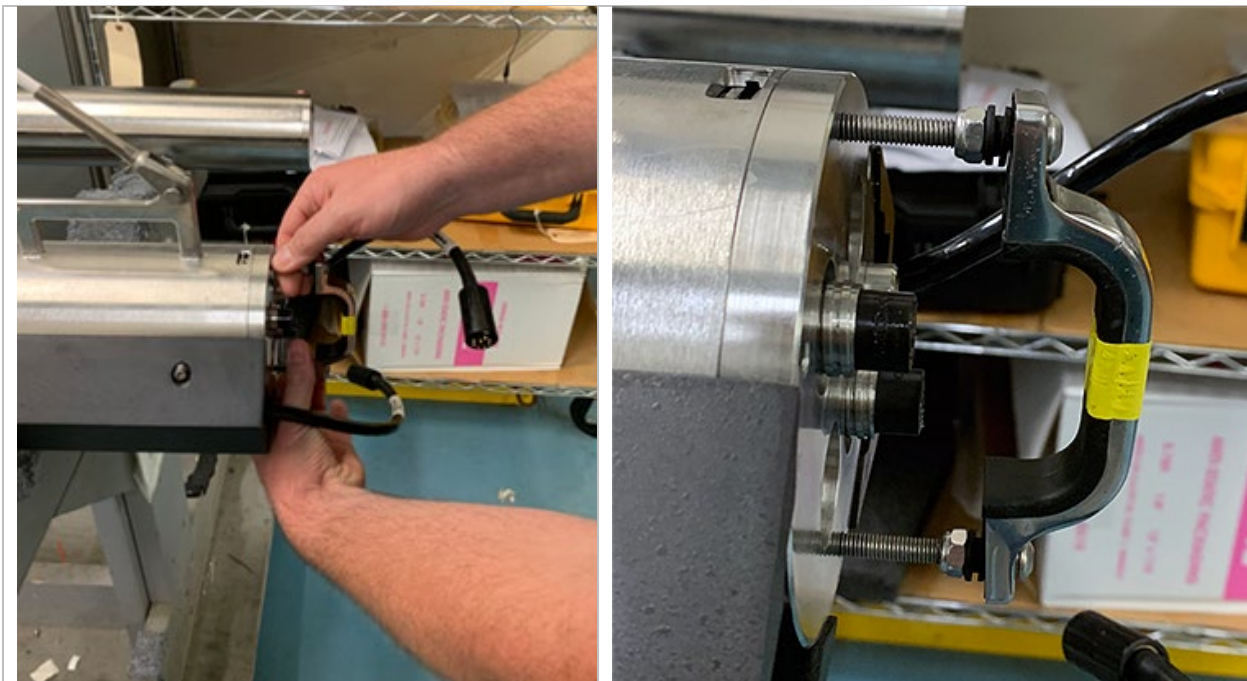

Figure 7-7: Aft Endcap Grip Handle Installation

10. Carefully pull the attached supplied grip handle to remove the electronics chassis from the housing and place it on a clean, dry, flat surface.



Figure 7-8: Electronics Chassis Removal From Towfish Housing

7.1.2 Assembling the Tow Vehicle

To assemble the tow vehicle, reverse the disassembly procedure. Checking and cleaning all O-ring surfaces before reassembling the vehicle is important. The O-ring surface should be debris-free and only cleaned with a lint-free cloth. EdgeTech recommends that the O-rings should be greased and replaced to ensure a watertight seal.

7.2 Standard AHRS Calibration

The AHRS is calibrated at the EdgeTech manufacturing facility and should not require additional calibration. Should the AHRS in the Towfish lose its calibration, contact **CUSTOMER SERVICE** for assistance in recalibrating it.

7.3 Starmux IV / 701-DL Troubleshooting

SYMPTOM	PROBABLE CAUSE	CORRECTIVE ACTION
The green POWER indicator does not illuminate when the unit is turned on.	The POWER switch in the front or rear of the unit is not turned on.	Verify that both POWER switches are on.
	No AC power.	Verify that the Starmux IV is connected to AC power. Check the AC power source. Verify that the fuse is good.
	Amp fuses on the rear panel VAC connection are bad.	Check fuses for continuity. Replace if necessary.
	The indicator is not operating.	Open the unit and check the indicator LED and wiring.
The green LAN indicator does not illuminate when the unit is turned on.	The 375 VDC 2.5A fuse mounted to the rear panel is bad	Check the fuse for continuity. Replace if necessary.
	There is no connection between the digital link and the external Topside processor.	Check the LAN connections between the Starmux IV unit and the Topside processor.
	The indicator is not operating.	Open the unit and check the indicator LED and wiring.
The green LINK indicator on the Starmux IV continues to flash after several minutes, and no LINK is established.	The tow cable between the digital link and the tow vehicle is disconnected or faulty.	Check connections and tow cable.
	The modem settings on the digital link are incorrect.	Contact CUSTOMER SERVICE
	The towfish is faulty.	Check the unit using a different Towfish.
The DISCOVER survey software (if used on external Topside) reports, "Cannot ping Towfish."	LAN cable disconnected.	Check the LAN cable connection.
	The tow cable was disconnected.	Check the tow cable connection.

CONTINUED NEXT PAGE

Table 7-1: Troubleshooting Table

SYMPTOM	PROBABLE CAUSE	CORRECTIVE ACTION
The discover survey software (if used on external topside) reports, "cannot ping towfish."	The modem settings are incorrect.	Please contact CUSTOMER SERVICE for modem settings.
	The modem disconnected internally on the digital link.	Check all connections to the modem are correct per the wiring diagram.
	Improper settings in Discover (if used on external Topside).	Check that under "Configuration" pull-down "Network," the displayed address is 192.9.0.101 with "Port" set to 1700.
	The tow vehicle is faulty.	Verify the tow vehicle using a different digital link. Verify the digital link with a different tow vehicle.

Table 7-1: Troubleshooting Table (Continued)

7.4 4205 Rack Mount Troubleshooting Guide

This troubleshooting section is for the Topside and Computer Combination

SYMPTOM	PROBABLE CAUSE	CORRECTIVE ACTION
The Blue Power Indicator on the 2U CPU does not illuminate	The POWER switch is not turned on.	Verify that the POWER switch located on the rear panel of the CPU is in the on position.
	No AC power.	Verify that the 2U CPU is connected to AC power. Check the AC power source.
	The indicator is not operating.	Open the topside and check the indicator and wiring.

Table 7-2: Rackmount Troubleshooting Chart

7.5 Towfish Troubleshooting Guide

The 4205 Towfish is a complex computer-controlled system requiring engineering expertise and the proper test equipment. For any service or troubleshooting, please contact **EDGETECH CUSTOMER SERVICE**

for updated instructions, drawings, documentation, tools, and guidance. This ensures success and is necessary to maintain the product's warranty.

The following sections provide specific areas to check and easily identifiable clues to look for in making an educated guess as to the source of the problem. This troubleshooting guide's scope only covers down to the module or printed circuit board (PCB) level.

7.5.1 Required Equipment

Except for the Topside processor/power unit, only common laboratory test equipment and tools are required for field troubleshooting. No special equipment is necessary. Typical test equipment includes:

- Digital multi-meter, Fluke, or equivalent
- Oscilloscope
- Hi-pot tester
- Capacitance meter

7.5.2 4205 vehicle

Before troubleshooting the towfish, verify that the command and data links between the towfish and topside are working, as described in [7.5.5 COMMAND AND DATA LINK](#).

NOTE: It is recommended that all attempts be made to see if a problem is external to the towfish before opening it. Also, contact EdgeTech for approval to open the towfish chassis to avoid voiding the warranty.

WARNING! When powered, high voltage (400 VDC) is always present in the electronics assembly.

7.5.2.1 No Sonar Data

If the sonar display does not scroll, use the 'scope sniffing' approach outlined in sub-section [7.5.3 TRANSMISSION VERIFICATION](#) to check transducer firing. If the transducers are firing, the data link works; the problem is most likely related to the Topside processor and/or data modem.

If the display scrolls but is blank, and the transducers are firing, the problem is likely with a combination of the Towfish receiver (MP mode) and/or its signal processing circuitry. The user should establish whether the problem is on a single or all channels.

If data is absent from all or individual channels, check the SAIBu board. If the problem is with a channel, also check the respective power amplifier and transducer array.

Connect to the Towfish using REMOTE DESKTOP 192.9.0.101 login: administrator, password: admin. The Sonar application should be running, and no errors should be posted to the window.

7.5.2.2 Reported Errors

REPORTED ERROR	INDICATION
“No Sonar Device Found”	Indicates the CPU does not connect to the sonar processor card
“IF_DIAG”	This indicates that the Sonar Processor has detected an error and will not run. Cycle power on Towfish recheck error. Check the cables running to and from the Sonar Interface Card if an error is still present.
HM_Sensors”	Indicates the 48 volts of the operating power supply. If this error is found, check the output of the power distribution board in Towfish and the power on the power amps.

Table 7-2: Reported Errors

7.5.2.3 Other Checks

An additional internal check is to verify the integrity of the sea ground capacitor attached to the end cap assembly. A sea ground is necessary for proper system operation and provides a path for electrical noise to travel away from the sensitive receiver electronics. When testing on a bench or a pool, a ground wire must be secured to the vehicle housing and connected to an earth ground. An AC outlet ground is a poor choice for an earth ground, but it can be used when no other options are available.

7.5.3 Transmission Verification

The 4205 Towfish differs from older conventional side scan sonars in that the “listen for the clicking noise” test cannot be used to verify sonar transmission. Earlier sonars were driven using large transformer relays that made an audible sound when driven. The digital drive amplifiers no longer have this pronounced clicking noise emanating from the 4205 when they are firing.

“Sniffing” with an oscilloscope can be used as a substitute to check transducer firing. One way is to attach the scope probe’s ground to the towfish body and hold the open probe next to the transducer under test. Set to 20 to 50mV /div. This method will detect if electrical energy is being delivered to the transducer, but it will not identify if there is internal damage to the transducer’s elements.

A second method is to connect a several-turn wire loop across the scope probe and move it over the transducer face. Electrical pickup should be noticed on the scope screen at each transmission burst. Remember that the transducers and elements within the transducer may be firing together or in sequence. Ensure that the electrical pickup is not from an adjacent string by activating only one frequency at a time.

7.5.4 Topside Power Unit

Towfish power is supplied from an integrated topside processor. Towfish voltage and current to the towfish are important parameters as they must be within acceptable limits for the towfish to work

properly. Check the tow cable output voltage with the system connected and, if possible, the current drain with an inline meter or inductive cable clamp connection. The cable current should be between 120mA (Idle) and 250mA.

The topside supplies 400VDC through the tow cable. The voltage at the towfish end of the cable must be not less than 300VDC to start the system and not be less than 200V during operation.

7.5.5 Command and Data Link

A successful Remote Desktop session can verify that the command and data link functions are operating through the tow cable. Please contact **CUSTOMER SERVICE** for assistance establishing a remote desktop connection or having an EdgeTech technician attempt a remote interface on the vehicle.

7.5.6 Data Link

A good, quick, qualitative test of the data link and towfish electronics is to perform a rub test on each transducer. Set the range to 100 meters for both frequencies and start the system running in HDM mode for both. Set screen gain to +30dB for both frequencies and briskly rub each aft transducer face one at a time. A cloth placed between the user's hand and the array face will improve the energy transfer. A dark band corresponding to the side rubbed should appear on the sonar processor screen.

Data throughput rates on the uplink (fish to topside) can be critical in getting smooth data from the towfish. The data throughput rate can be checked using EdgeTech-supplied utilities.

The *SockBlast* application is used to test network throughput between the 4205 Towfish and the Topside computer. This application is normally kept in the *C:\EdgeTech\Utilities* folder on the topside unit and *D:\EdgeTech\Utilities* folder on the towfish.

Two copies of SockBlast must be run, with one installed on the towfish acting as a server and another running on the topside acting as a client.

SockBlast Operational Instructions are as follows:

On the Towfish Side

1. Set the server's IP address to match the desktop computer's IP address (192.9.0.99), and press **Create Server**.
2. Check the **Send Data from Server to Client** checkbox to start the process of sending data (**FIGURE 7-9**).

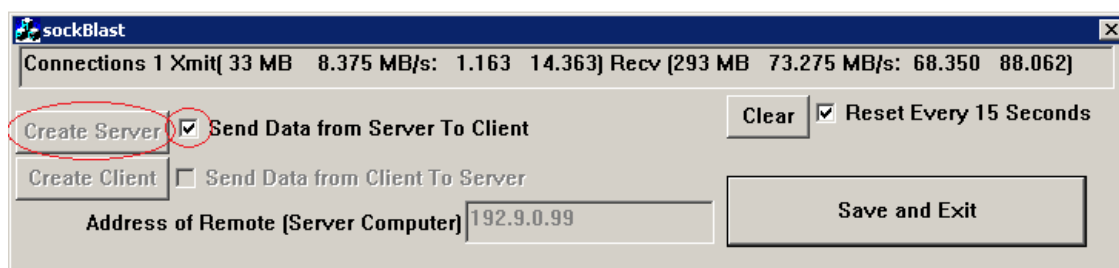

Figure 7-9: SockBlast on Towfish Side

From the Topside Computer

3. Set the IP Address to 192.9.0.101, then press **Create Client**
4. Check the **Send Data from Client to Server** checkbox on the *SockBlast* software running on the vehicle's embedded computer (**FIGURE 7-10**).

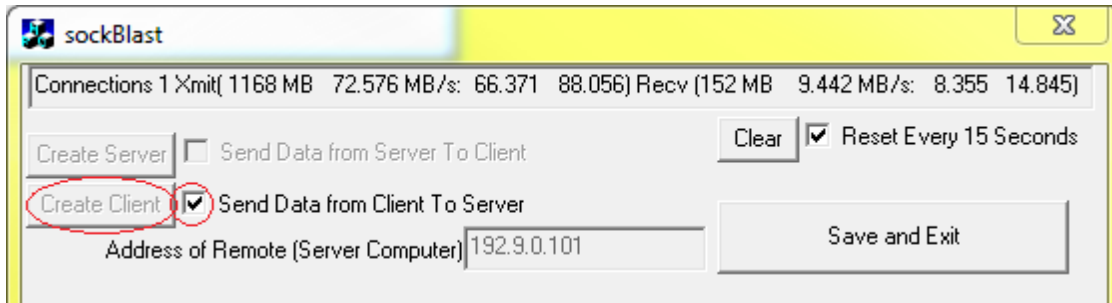

Figure 7-10: Sockblast Client on Topside Computer

After pressing the **Create** buttons to start the server and clients on their respective machines, the two applications will synchronize their data stream, as evident by the Client and Server counters. The Client count on the towfish should increment from 0 to 1, and the Server count on the topside should increment to 1 as well. This indicates one connection between the two applications.

Check the **Server Send Data** box on the Towfish. A performance in MB/second will be displayed. This should be more than 0.35Mbyte/s.

7.6 Tow Cable Troubleshooting

Historically, most system problems occur with the tow cable and its connectors. Before proceeding, verify cable continuity from the shipboard end of the cable to the towfish. The presence of a shorted or open wire in a tow cable can be determined by using a multimeter. An open or shorted wire can be located using the techniques described in the following subsections.

7.6.1.1 Shorted Wire

The following procedure may be used to approximate the distance to a single short or a point of high leakage between a conductor pair or from a conductor to a shield.

1. Disconnect both cable ends.
2. Short the two connector pins (or wires if un-terminated) of the shorted pair at both ends and measure the total resistance between the ends.

$$R1 + R2 = \underline{\hspace{2cm}}$$

3. Remove the shorts.
4. Measure the resistance between a shorted pair on one end with an ohmmeter on the Rx1 scale.

$$R1 + R_s = \underline{\hspace{2cm}}$$

5. Measure the resistance from the other end.

$$R2 + R_s = \underline{\hspace{2cm}}$$

6. Add the measurements of **STEP 4** and **STEP 5**. Subtract the measurement of **STEP 2**, and divide the result by 2.

$$R_s = \underline{\hspace{2cm}}$$

7. Subtract the value of 6) from the measured values of 4) and 5).

$$R1 = \underline{\hspace{2cm}}$$

$$R2 = \underline{\hspace{2cm}}$$

8. The distance to the short from end #1 is the ratio of $(R1/R1+R2)$ times the total cable length. Recheck from end #2, which is $(R2/R1+R2)$ times the cable length.

7.6.1.2 Open Wire

An open wire is much more challenging to locate than a short circuit. Therefore, a capacitance bridge is recommended. Measuring the open wire's capacitance to the shield on both ends allows two different capacitance readings to be recorded. This represents a direct ratio related to cable length and distance of break from each end. Before cutting the cable, double-check the same capacitance ratio using an adjacent good wire in a multi-conductor cable. The capacitance may vary from wire to wire, depending on their separation.

Most breaks occur around the termination of the tow cable or where a previous repair has been made. A cable break may be found or confirmed by laying out the cable and attaching an Ohmmeter across each end of the open wire. Then, flex the cable first near the termination or repaired section and then along its entire length until the break is reached. When flexing, the broken wire ends may touch, giving a continuity reading on the meter.

7.6.1.3 Insulation Resistance Breakdown

Insulation breakdown is the most difficult fault to locate. Cable leakage is not necessarily located near the end of terminations. However, the area near each termination receives the most abuse and is subject to suspicion. Successive cutting of the cable end until leakage disappears will often prove successful.

CAUTION! Before cutting the cable for any of the above reasons, a careful visual examination should be made for any signs of physical damage.

The tow cables should measure between 100 Mega-ohms and infinity between conductors with a 500 VDC Megohmmeter with both ends disconnected. When using a Simpson 260 Multimeter, all wire-to-wire or wire-to-shield cables should measure infinity.

Any leakage on the multimeter indicates cable leakage.

7.6.1.4 Damaged Tow Cable Connector

The towfish has a safety/trip line that prevents the vehicle from being snagged on an underwater object. When the line trips, the cable connection to the towfish disconnects, exposing the high-voltage pins to seawater. Pin corrosion will start to occur as long as power is still applied. Power should be immediately terminated at the topside when detected to prevent further damage to the vehicle and crew members' safety during recovery. Any exposed electrical connections will require cleaning and re-termination.

A.0 4205 KITS

A.1 4205 MPMT Spare Kits

0020596_REV_F ASSY TOP KIT SPARES 4205 MP 100-400 KHZ TOW FISH			
MTL	Part	Description	QTY
10	0025342	ASSY SUB BOARDSET E3825 CPU COM EXPRESS SLIM HEATSINK ON PCIEX CARRIER NO STANDOFFS	1
20	0006125	PCB ASSY POWER AMP ANALOG 4200	1
30	0021004	PCB ASSY TOP SIM2XA 4205 120-410 KHZ MP	1
40	0025229	PCB ASSY TOP SONAR ACQUISITION INTERFACE BOARD PCIEX SAIBX	1
50	0020326	ASSY SUB CABLE 4205 CAP BANK LOCAL	1
60	0024215	PCB ASSY TOP POWER SUPPLY UNIT SYNCED 4205	1
70	0025691	ASSY SUB CABLE 4205 USB-C 1.0M WITH FERRITE	1
80	0017144	MEMORY FLASH GENERIC R-DRIVE IMAGE KONTRON E38XX CPU	1
90	0020341	SOFTWARE EDGETECH FOLDER 4205 TOW FISH	1
100	0023061	PCB ASSY TOP INTERFACE MESTECH MODEM TDSL 1006	1

Table 7-3: 4205 MPMT 100-400 kHz Spare Kit

0021509_REV_C ASSY TOP KIT SPARES 4205 MP 230-540 KHZ TOW FISH			
MTL	Part	Description	QTY
10	0025342	ASSY SUB BOARDSET E3825 CPU COM EXPRESS SLIM HEATSINK ON PCIEX CARRIER NOSTANDOFFS	1
20	0006125	PCB ASSY POWER AMP ANALOG 4200	1
30	0021005	PCB ASSY TOP SIM2XA 4205 230-540 KHZ MP	1
40	0025229	PCB ASSY TOP SONAR ACQUISITION INTERFACE BOARD PCIEX SAIBX	1
50	0020326	ASSY SUB CABLE 4205 CAP BANK LOCAL	1
60	0024215	PCB ASSY TOP POWER SUPPLY UNIT SYNCED 4205	1
70	0025691	ASSY SUB CABLE 4205 USB-C 1.0M WITH FERRITE	1
80	0017144	MEMORY FLASH GENERIC R-DRIVE IMAGE KONTRON E38XX CPU	1
90	0020341	SOFTWARE EDGETECH FOLDER 4205 TOW FISH	1
100	0023061	PCB ASSY TOP INTERFACE MESTECH MODEM TDSL 1006	1

Table 7-4: 4205 MP 230-530 kHz Spare Kit

0021218_REV_C ASSY TOP KIT SPARES 4205 MP 230-850 KHZ TOW FISH			
MTL	Part	Description	QTY
10	0025342	ASSY SUB BOARDSET E3825 CPU COM EXPRESS SLIM HEATSINK ON PCIEX CARRIER NOSTANDOFFS	1
20	0006125	PCB ASSY POWER AMP ANALOG 4200	1
30	0021217	PCB ASSY TOP SIM2XA 4205 230-850 KHZ MP	1
40	0025229	PCB ASSY TOP SONAR ACQUISITION INTERFACE BOARD PCIEX SAIBX	1
50	0020326	ASSY SUB CABLE 4205 CAP BANK LOCAL	1
60	0024215	PCB ASSY TOP POWER SUPPLY UNIT SYNCED 4205	1
70	0025691	ASSY SUB CABLE 4205 USB-C 1.0M WITH FERRITE	1
80	0017144	MEMORY FLASH GENERIC R-DRIVE IMAGE KONTRON E38XX CPU	1
90	0020341	SOFTWARE EDGETECH FOLDER 4205 TOW FISH	1
100	0023061	PCB ASSY TOP INTERFACE MESTECH MODEM TDSL1006	1
110	0006127	PCB ASSY TOP POWER AMP ANALOG 850 KHZ 4200 VHF	1

Table 7-5: 4205 MP 230-850 kHz Spare Kit

A.2 4205 Tri-Frequency Spare Kits

0021880_REV_D ASSY TOP KIT SPARES 4205 TRIFREQUENCY 120 410 850 KHZ TOW FISH			
MTL	Part	Description	QTY
10	0025342	ASSY SUB BOARDSET E3825 CPU COM EXPRESS SLIM HEATSINK ON PCIEX CARRIER NO STANDOFFS	1
20	0021843	PCB ASSY TOP POWER AMP DUAL DIGITAL DDPA 120 KHZ RLJ1669 PASSIVE	1
30	0021844	PCB ASSY TOP SONAR INTERFACE MODULE II SIM2 4205 410KHZ - 850KHZ	1
40	0025229	PCB ASSY TOP SONAR ACQUISITION INTERFACE BOARD PCIEX SAIBX	1
50	0022007	ASSY SUB CABLE 4205 TRIFREQUENCY CAPACITOR BANK TO DDPA	1
60	0024215	PCB ASSY TOP POWER SUPPLY UNIT SYNCED 4205	1
70	0025691	ASSY SUB CABLE 4205 USB-C 1.0M WITH FERRITE	1
80	0017144	MEMORY FLASH GENERIC R-DRIVE IMAGE KONTRON E38XX CPU	1
90	0022031	SOFTWARE EDGETECH FOLDER 4205 TOW FISH	1
100	0023061	PCB ASSY TOP INTERFACE MESTECH MODEM TDSL 1006	1
110	0012699	ASSY SUB 2205 STORAGE CAPACITOR 12 SIM 9840UF 63VDC	1
120	0023493	ASSY SUB 2205 STORAGE CAPACITOR 06 SIM2 4920UF 63VDC	1

Table 7-6: 4205 Tri-Frequency 120/410/850 Spare Kit

0021881_REV_D ASSY TOP KIT SPARES 4205 TRIFREQUENCY 230 540 850 KHZ TOW FISH

MTL	Part	Description	QTY
10	0025342	ASSY SUB BOARDSET E3825 CPU COM EXPRESS SLIM HEATSINK ON PCIEX CARRIER NO STANDOFFS	1
20	0018384	PCB ASSY TOP POWER AMP DUAL DIGITAL DDPA 230 KHZ RLJ1212 6000M	1
30	0021680	PCB ASSY TOP SONAR INTERFACE MODULE II SIM2 4205 540KHZ - 850KHZ	1
40	0025229	PCB ASSY TOP SONAR ACQUISITION INTERFACE BOARD PCIEX SAIBX	1
50	0022007	ASSY SUB CABLE 4205 TRIFREQUENCY CAPACITOR BANK TO DDPA	1
60	0024215	PCB ASSY TOP POWER SUPPLY UNIT SYNCED 4205	1
70	0025691	ASSY SUB CABLE 4205 USB-C 1.0M WITH FERRITE	1
80	0017144	MEMORY FLASH GENERIC R-DRIVE IMAGE KONTRON E38XX CPU	1
90	0022031	SOFTWARE EDGETECH FOLDER 4205 TOW FISH	1
100	0023061	PCB ASSY TOP INTERFACE MESTECH MODEM TDSL 1006	1
110	0012699	ASSY SUB 2205 STORAGE CAPACITOR 12 SIM 9840UF 63VDC	1
120	0023493	ASSY SUB 2205 STORAGE CAPACITOR 06 SIM2 4920UF 63VDC	1

Table 7-7: 4205 Tri-Frequency 120/540/850 Spares Kit

A.3 Tool Kit

0020480_REV_1 ASSY SUB KIT 4205 HARDWARE/TOOLS			
Mtl	Part	Description	Qty
10	0005364	HARDWARE SCREW METRIC MACHINE FLAT HD 82 PHILLIPS M4 0.70MM 10MM 18-8 SS	2
20	0005367	HARDWARE SCREW METRIC MACHINE LOW HD SOCKET M5 X 0.80MM HEX 10MM 316 SS	16
30	0007181	HARDWARE WASHER METRIC FLAT M5 316 SS	16
40	0007226	HARDWARE WASHER METRIC SPLIT LOCK M5 316 SS	16
50	0005371	HARDWARE SCREW METRIC MACHINE SOCKET HD 1MM HEX M6 45MM 316 SS	4
60	0019826	HARDWARE WASHER METRIC SPLIT LOCK M6 316 SS	4
70	0007182	HARDWARE WASHER METRIC FLAT M6 316 SS	4
80	0020968	TOOL HEX KEY BALL END T HANDLE 5MM	1
90	0020969	TOOL HEX KEY BALL END T HANDLE 4MM	1
100	0006970	TOOL SCREWDRIVER PHILLIPS 01	1
110	0006968	TOOL PLIER W/SIDE CUTTERS	1
120	0019478	LABEL SHEET WHITE MAILING 04 INCH 1.33 INCH	1
130	0021213	DOC TEMPLATE 4205 HARDWARE / TOOLS KIT LABEL SET	1

Table 7-8: 4205 Tool Kit